

BPMS FOR THE XFEL CRYO MODULE

D. Nölle, N. Baboi, K. Knaack, D. Lipka, N. Mildner, R. Neumann, M. Siemens, T. Traber, S. Vilcins, DESY, 22603 Hamburg, Germany

Abstract

The European XFEL is based on superconducting accelerator technology developed in the context of the TESLA collaboration [1]. The accelerator itself consists of cryo modules equipped with 8 cavities, followed by a quadrupole/steerer package, a BPM and a HOM absorber. This contribution will present the layout of the BPM system for the cryo modules, describing the monitor itself, its integration into the cryo module. Additionally, the electronics concept will be discussed. Finally the results of beam measurements at FLASH using prototypes of the monitor and the electronics will be presented

INTRODUCTION

The accelerator complex of the European XFEL at DESY consist of a superconducting LINAC with a maximum energy of about 20 GeV. It is constructed out of 116 cryo-modules, with only a few warm sections intercepting the cold acceleration chain. The only monitor devices in the cold sections are BPMs, one per cryo module. They have to provide position and charge information along the LINAC.

Two BPM types are currently under investigation, a re-entrant cavity BPM developed by CEA in collaboration with DESY [2], and a button type BPM. The latter will be the topic of this paper.

Table 1: Requirements of the BPM

Parameter	Value
charge	0.1 – 1 nC
Bunch Spacing	200 ns (\geq , arbitrary pattern)
Position Resolution	< 50 μ m (Single Bunch)
Charge Resolution	1 %
#Datapoints	3250 within 650 μ s @ 30 Hz
Length	170 mm
Beam Pipe	78 mm
Operation Temp.	4 – 20 °K

INTEGRATION INTO THE XFEL CRYO MODULE

The XFEL cryo module houses 8 TESLA cavities followed by a superconducting magnet block, consisting of a superferric quadrupole and a set of steerers. The BPM is connected to the vessel of the magnet. Components to follow are a gate valve and the HOM absorber. Fig. 1 shows the layout of the end of the cryo module in detail.

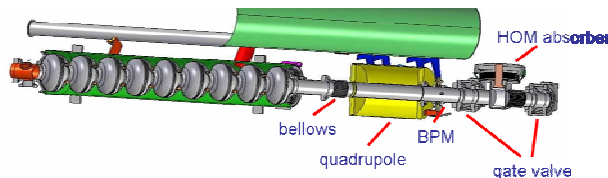

Figure. 1: Layout of the back part of the XFEL Cryo module.

In contrast to module BPMs at FLASH [3] (former TTF), the BPMs are flanged and not welded to the beam pipe. The BPM has a length of 170 mm, with two fixed, so called “cavity flanges” on both sides. The beam pipe diameter is 78 mm, the inner beam pipe has to be copper plated. Since the BPM is connected to the liquid He vessel of the quadrupole, the BPM will be at a temperature close to the 4 k level. The vicinity of the superconducting cavities requires a particle free inner volume of the BPM (Cleanroom Class 100). The alignment to the magnetic axis and orientation of the quad has to be better than 300 μ m (transverse) and 3 mrad (roll angle) The cables of the BPM have to be a compromise between low cryogenic losses and RF properties.

BPM MECHANICS

Following the requirements on the mechanics inside the module a pickup monitor was designed. It is foreseen to mill the BPM out of a single piece, providing optimum tolerances and safety from the vacuum point of view. The alignment to the adjacent quadrupole will be based on field measurements of the quad and the use of dowel pins, included in the mechanical design of the BPM, in order to meet the tolerances mentioned before.

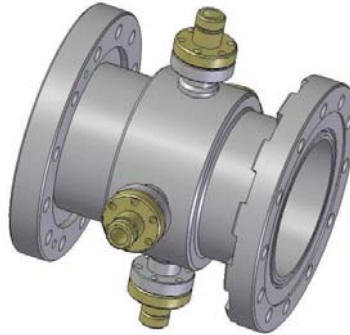

Figure 2: 3D Model of the BPM prototype

The design of a prototype is shown in Fig. 2. In order to meet the requirements at the lower charge limit, a feedthrough design with a larger button size of 15 mm is currently under investigation. Therefore, there will be some changes concerning the flanges for the feedthroughs and the feedthroughs themselves.

ELECTRONICS CONCEPT

As mentioned in Table 1, the bunch to bunch distance in XFEL is as long as 200 ns. Furthermore, the requirement is a single bunch, single pass resolution better than 50 μm . These requirements are close to the performance of the electronics type used for the DESY electron rings, typically operating with a bunch spacing of 96 ns [4]. Here the signals of the 4 buttons are added onto a single cable after running through delay lines of certain length. Thus the electronics gets a sequence of 4 pulses for processing. The influence of the delaylines is taken out by means of calibration. Due to the use of a single electronics channel, one gets good stability properties. XFEL will use a modified and updated version of this scheme. Due to the geometry of the XFEL BPMs it is easy to separate the vertical and the horizontal plane and to process them by separate electronics. Thus there will be one electronic per plane.

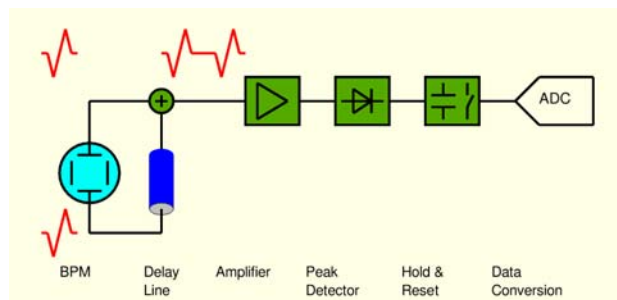

Figure 3: Block diagram of the BPM electronics for the pickup BPMs

In order to deal with drifts of the delay line network a test and calibration facility will be included in each electronic. It will allow to send and analyse test pulsed before or after each RF pulse of the linac, for testing and online calibration.

Since there will be various types of BPMs for XFEL this electronics has to be integrated into an overall framework of a BPM system. Currently this framework is under discussion with the colleges from PSI who plan to collaborate with XFEL on the warm BPM system. It is planned to integrate this electronics, including analog front end to ADC as a piggy pack board to be mounted on a common processing board. The cold BPM electronics would appear like an ADC unit to the processing board.

Based on the test setups the layout of the PCB for a prototype series is under development, and prototype boards will be available for testing in summer 07. Beam test at FLASH are scheduled for fall 07.

BEAM RESULTS AT FLASH

A prototype of this XFEL BPM with adapted flange type (CF) and 8 mm buttons (as shown in Fig 2.) was installed in the FLASH LINAC. Several studies have been performed with this monitor and different test setups for the electronics. The result of a measurement with this BPM and a first electronics prototype is shown below.

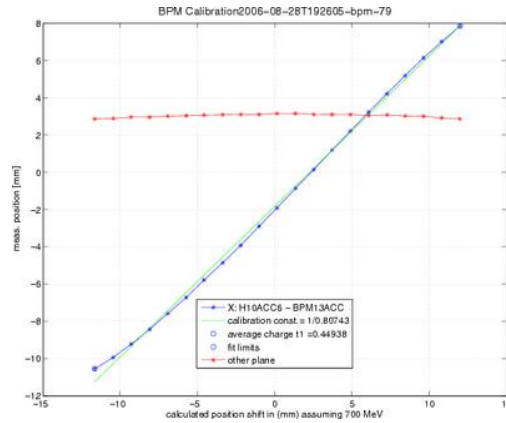

Figure 4: BPM response vs. steerer current at FLASH

The BPM was included in resolution measurements using correlation techniques [5]. For different charges in the range of 0.2 to 1 nC the resolution was measured to be better than 30 μm . Dynamic range of ± 15 mm was also demonstrated, as well as a the required charge resolution of 1%.

CONCLUSION

In this paper the design and first measurements of a prototype for the BPMs in the XFEL cryo modules are presented. With the current design for a button type monitor and an electronics based on the scheme used at HERA, the requirements for XFEL can be met.

REFERENCES

- [1] XFEL Technical Design Report, DESY 2006-97; XFEL.desy.de
- [2] C. Simon et al, this proceeding.
- [3] V. Ayvazyan, et al., "First operation of a Free-Electron Laser generating GW powerradiation at 32 nm wavelength", Eur. Phys. J. D37 (2006) 297.
- [5] R. Neumann, private Communication
- [6] N. Baboi, "Resolution Studies a BPMs at the FLASH Facility at DESY", Proc BIW 06, 227