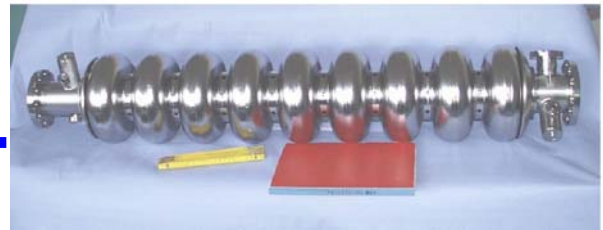

**SRF**

Status of the Electron Beam Transverse Diagnostics with Optical Diffraction Radiation at FLASH, DESY

E. Chiadroni, M. Castellano,
Laboratori Nazionali di Frascati - INFN, via E. Fermi, Frascati, Italy

A. Cianchi,
Universita di Roma "Tor Vergata", via della Ricerca Scientifica, Roma, Italy

K. Honkavaara,
Universitat Hamburg, Inst. f. Experimentalphysik, Luruper Chaussee, Hamburg

G. Kube
Deutsches Elektronen-Synchrotron, Hamburg, Germany

Abstract

The characterization of the transverse phase space of electron beams with high charge density and high energy is a fundamental requirement for particle accelerator facilities. The knowledge of characteristics of the accelerated beams is of great importance also for the successful development of the next generation light sources and linear colliders. In order to measure the properties of such beams, development of non-invasive and non intercepting beam diagnostics techniques is necessary. A promising candidate is Optical Diffraction Radiation (ODR), as testified by the interest of many laboratories all around the world. At this purpose, an experiment using ODR to measure the electron beam transverse parameters has been set up at FLASH (former VUV-FEL) at DESY (Hamburg). Radiation emitted by 620 MeV electron beam passing through a 1 mm slit on a screen made of aluminum deposited on a silicon substrate is detected by a low noise, high sensitivity CCD camera. We report here the status of this experiment.

Contribution to the Channelling 2006, Frascati (Rome), Italy

Work supported by the European Community-Research Infrastructure Activity under the FP6 "Structuring the European Research Area" programme (CARE, contract number RII3-CT-2003-506395)

Status of the Electron Beam Transverse Diagnostics with Optical Diffraction Radiation at FLASH, DESY*

E. Chiadroni^{†a}, M. Castellano^a, A. Cianchi^b, K. Honkavaara^c, G. Kube^d

^aLaboratori Nazionali di Frascati - INFN, via E. Fermi, 40, 00044 Frascati, Italy;

^bUniversità di Roma “Tor Vergata”, via della Ricerca Scientifica, 1, 00133 Roma, Italy;

^cUniversität Hamburg, Inst. f. Experimentalphysik, Luruper Chaussee 149, 22761 Hamburg, Germany;

^dDeutsches Elektronen-Synchrotron, Notkestraße 85, 22607 Hamburg, Germany

ABSTRACT

The characterization of the transverse phase space of electron beams with high charge density and high energy is a fundamental requirement for particle accelerator facilities. The knowledge of characteristics of the accelerated beams is of great importance also for the successful development of the next generation light sources and linear colliders.

In order to measure the properties of such beams, development of non-invasive and non-intercepting beam diagnostics techniques is necessary. A promising candidate is Optical Diffraction Radiation (ODR), as testified by the interest of many laboratories all around the world.

At this purpose, an experiment using ODR to measure the electron beam transverse parameters has been set up at FLASH (former VUV-FEL) at DESY (Hamburg). Radiation emitted by 620 MeV electron beam passing through a 1 mm slit on a screen made of aluminum deposited on a silicon substrate is detected by a low noise, high sensitivity CCD camera.

We report here the status of this experiment.

Keywords: Optical Diffraction Radiation, DESY, Beam Diagnostics, FEL

1. INTRODUCTION

The development of high energy Linear Collider and short wavelength Free Electron Laser (FEL) requires high quality electron beams, whose power density is so large that no intercepting device can sustain it. Therefore, new non-intercepting diagnostics devices need to be developed.

A new method for the non-intercepting measurement of beam size was suggested in 1996.¹ The idea is based on the observation of Diffraction Radiation (DR) emitted by a charged particle beam going through a slit in a metallic foil due to the interaction of the electromagnetic (EM) field of the charge with the boundary. The DR angular distribution is produced by the interference of radiation from both edges of the slit. The visibility of the interference fringes is correlated to the beam size. The effect is also affected, in a slightly different way, by the angular divergence of the beam: the angular distribution of Optical Diffraction Radiation (ODR) becomes wider and the intensity of the minimum higher, when the beam divergence increases.

A first measurement of beam parameters with ODR diagnostics has been performed at ATF KEK² in 2004. Last results of this experiment have been shown in this conference by A. P. Potylitsyn.³

Our experiment is carried out at FLASH, Free electron LASer in Hamburg, at DESY (Hamburg, Germany). For this kind of experiment, FLASH is an excellent facility because due to the superconducting accelerator technology, it can drive long train pulses, up to 800 bunches per macropulse, which means high charge operation,

* Work supported by the European Community Infra-structure Activity under the FP6 “Structuring the European Research Area” program (CARE, contract number RII3-CT-2003-506395)

[†]enrica.chiadroni@lnf.infn.it; phone: +39 06 9403 2465

good long term stability, small beam transverse emittance, < 2 mm mrad, and high energy, 1 GeV in the next future.

Most of the time FLASH is operated as a user facility providing FEL radiation in wavelength range from vacuum ultraviolet to soft X-rays for FEL experiments. Since FEL radiation is produced when a high quality electron beam passes through an undulator, the operation of FLASH is optimized to provide required beam properties in the entrance of the undulator. Our experimental set-up is mounted on by-pass beam line, which by-passes the undulator and guides the electron beam to the dump when the transport through the undulator is not required. Since the electron beam is optimized for FEL operation, tuning is typically required to provide required electron beam properties on the location of our experiment. During measurements reported in this paper, FLASH was operated in the first period with 480 MeV and in the second period with 620 MeV electron beam energy. With present layout of five superconducting accelerator modules, the maximum beam energy is around 700 MeV. In spring 2007, when an additional module will be installed, the energy will be increased up to 1 GeV. In our measurements we used up to 30 electron bunches (1 nC) per macropulse with 1 MHz bunch spacing. The macropulse repetition rate was 5 Hz.

In this paper we report the status of ODR experiment and we will show some preliminary results from the first set of measurements.

2. DR GENERAL FEATURES

Diffraction radiation is produced when a charged particle goes through a slit or passes by the edge of a metallic screen, due to the interaction between the EM field of the traveling charge and the target surface.⁴ The intensity of the radiation is proportional to $e^{-\frac{2\pi a}{\gamma\lambda}}$, where a is the slit aperture, γ the Lorentz factor and λ the emitted wavelength. The factor $\frac{\gamma\lambda}{2\pi}$, called as DR impact parameter, is a unit of measure of the radial extension of the EM field, representing a natural unit of measure of this phenomenon. In case of $a \gg \frac{\gamma\lambda}{2\pi}$, the aperture is much greater than the extent of the particle EM field, which does not interact with the target at all and therefore no radiation is produced. In the opposite case, if $a \ll \frac{\gamma\lambda}{2\pi}$, transition radiation is substantially emitted. We are interested in the case of $a \cong \frac{\gamma\lambda}{2\pi}$ for which DR is emitted.

Since the beam goes through the slit, DR is a non-intercepting diagnostics and therefore excellent to be used parasitically without disturbing the electron beam.

Due to the transverse beam size, in our experiment a typical slit aperture is of the order of mm or sub-mm. This means that in case of high energy, $\gamma \approx 10^3$, also optical wavelengths are emitted, allowing an easier detection of radiation, thanks to the wide instrumentation available, and the reconstruction of beam transverse parameters like position, transverse size, angular divergence. The angular distribution of the DR is mainly affected by beam parameters in the plane orthogonal to the slit aperture: when the transverse beam size is increased, both the peak intensity and the central minimum increase, resulting in the reduction of their ratio. The visibility of the interference fringes is also correlated to the beam size, as stated by a simulation plotted in Fig. 1a. The effect of the beam angular divergence is shown in Fig. 1b, resulting in the smoothing out of the maximum and minimum values as the beam angular divergence increases.

In our case, the slit is horizontal, allowing to measure the beam size and the beam angular divergence in the vertical plane, σ_y and σ'_y , respectively.

3. EXPERIMENTAL APPARATUS

The experimental set-up has an aluminated silicon screen (DR screen) mounted at 45° angle with respect to the beam direction. In order to minimize the contribution from synchrotron light, the set-up is placed as far as practically possible (50 m) from the by-pass dipole magnets (Fig. 2). A dedicated optical system has been studied and it will be described in section 3.2.

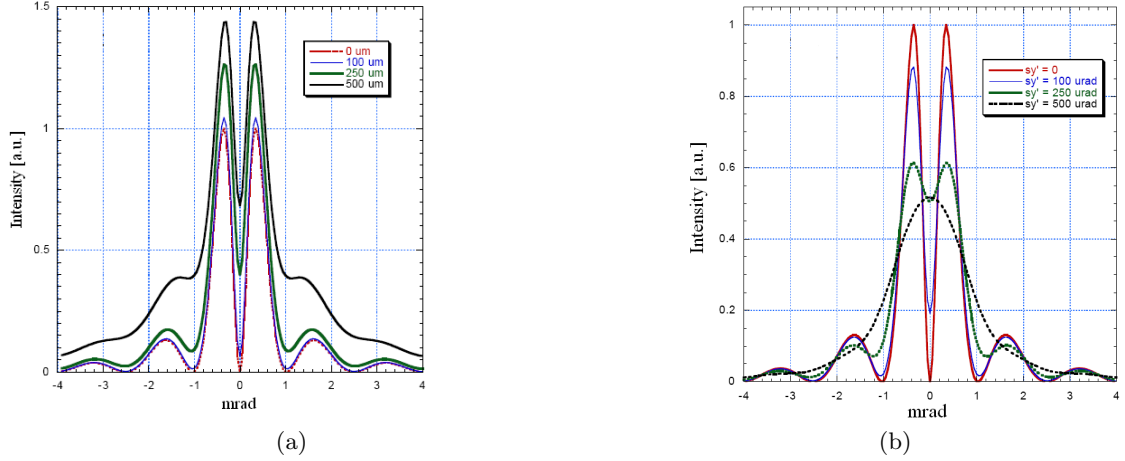

Figure 1. ODR angular distribution at 1 GeV for different beam sizes (a) and beam angular divergences (b).

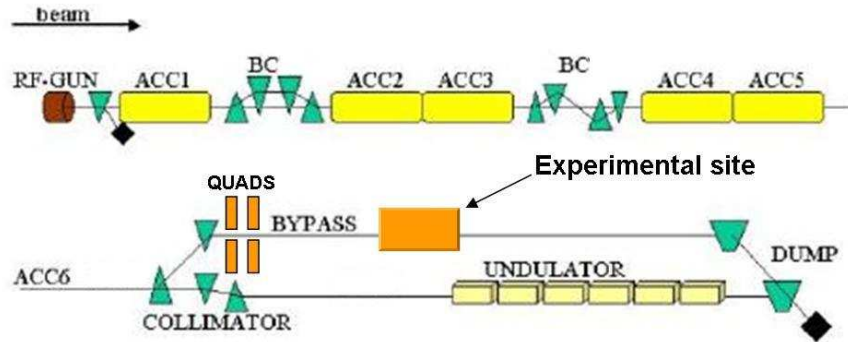

Figure 2. FLASH layout and experimental site.

3.1. Diffraction Radiator

The target plays an important role in the success of the experiment, since damaged edges and/or an uneven surface may change the interference effects, resulting in a non-significant angular distribution. Therefore, special care has been taken when manufacturing the target as well as during the measurements to avoid that the beam hits the edges. The target is constructed by lithographic technique starting from a silicon nitride wafer and opening two slits, one of 0.5 mm and the other of 1 mm aperture, with chemical etching. The slits are spaced by 2 cm, and the space between the slits is used as a standard OTR screen (Fig. 3). An aluminum layer is deposited by sputtering on the target to enhance the reflectivity .

3.2. Optical System

Radiation from the target is reflected by a mirror and sent through an optical system to the camera. Since the reflection power of the mirror surface is different for the horizontal and vertical polarizations, and the component parallel to the incident plane (the horizontal one) is reduced, the effect is a non-perfect annular OTR angular distribution as shown in Fig. 9a. Let us note that since the camera is rotated by 90° , vertical on the screen corresponds to horizontal and viceversa.

Two lenses, one to image the beam, the other one to produce the DR angular distribution, can be selected. They have different focal length in order to have the focus on the same plane. Two interferential filters, at 800 nm and 450 nm, and a polarizer may be inserted on the optical axis. Due to the very low radiation intensity, a



Figure 3. DR target.

cooled high sensitivity CCD camera[‡] is used. The camera main features are the very high quantum efficiency on the whole visible spectrum, negligible thermal noise and the long exposure time, up to 2 hours. The optical system layout is shown in Fig. 4.

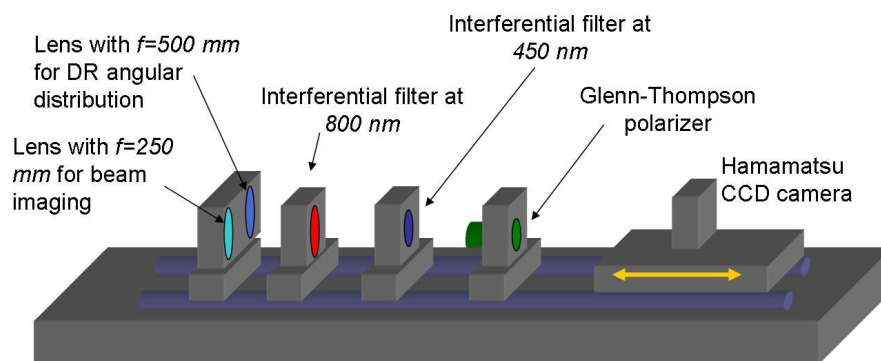

Figure 4. Sketch of the optical system.

3.3. Acquisition System

The optical system is remotely controlled by an electronic box, using can-bus modules, partially integrated in the linac control system and placed in the tunnel. The image acquisition and all related controls are driven via Firewire by a dedicated industrial PC.

4. PRELIMINARY RESULTS

So far the experiment has been performed in two periods: the first one at low energy, 480 MeV, necessary to test the whole apparatus (a rough energy measurement has been done with OTR) and to get a first understanding of the critical background; the second one at higher energy, 620 MeV, during which the first measurements with the 1 mm slit were performed. Furthermore, an offline background subtraction procedure allowed to obtain interesting preliminary results.

During both periods, the available measurement time did not allow us to optimize the beam parameters (e.g. transverse dimensions and stability) in the by-pass line such that the insertion of the 0.5 mm slit would have not been possible without damaging the screen.

An improved beam optics was calculated and based on this optics the beam size was minimized at the location of the ODR experiment by varying the strength of the quadrupoles before.

[‡]Hamamatsu C4742-98-LGLAG2.

4.1. Critical Issues

Since it was not possible during the measurements to optimize the beam optics and beam parameters in the bypass line, the contribution of the synchrotron light came not only from the dipole, but also from the quadrupole magnets upstream of our experiment, since quadrupole strengths were much stronger than the nominal one to minimize beam dimensions. Furthermore, synchrotron radiation was not diffuse as expected, due to multiple reflections on the beam pipe, and therefore the background is the image of our target (Fig. 5) from the source apparently placed at 2 – 3 m from the target itself. This means that the background comes with the beam and it is not trivial to eliminate (details in section 4.3).

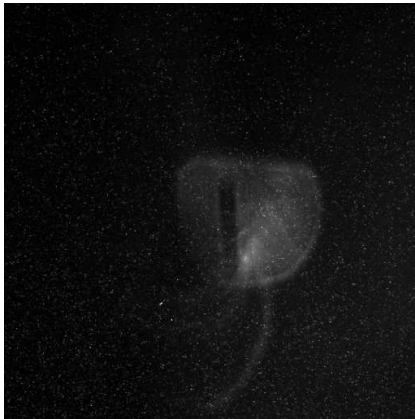

Figure 5. Background image taken when steering the beam out of the screen. Exposure time: 1 s.

A serious problem was the too large beam size together with relatively low beam energy, which made measurements difficult. Therefore, the optimization of the beam transport was crucial. We decided to operate with low charge per bunch (0.3 nC) to decrease the transverse emittance, and a large number of bunches (up to 30 per macropulse) to increase the signal intensity.

4.2. Beam Energy Measurement

During the first set of measurements with nominal beam energy of 480 MeV, a rough energy measurement has been done by measuring the aperture of the OTR angular distribution cone. Figures 6a and 6b show the OTR angular distribution and its projection, respectively.

The beam energy measured from the OTR angular distribution, 408 MeV, is in agreement with the nominal value within 20%, showing a reliable system response.

4.3. Background Subtraction

The main limitations during both periods of measurements were given by the background (Fig. 5) and the large amount of hot spots which did not allow us to increase the exposure time.

To separate the background from the beam, the beam need to be moved out of the screen by using steering magnets upstream of the target. However, since the steered beam hits the beam pipe, this procedure further increases the amount of emitted X-rays. At this regard, an off-line LabView tool which first eliminates X-rays by selecting a neighborhood with a 3×3 matrix, then subtracts the background image has been developed. In order to increase both signal and background intensity, the sum of N images, normalized to the number of images, is considered. Figure 7a shows the OTR angular distribution and the background image on the focal plane. The projected profile (Fig. 7b) does not show the typical OTR angular distribution profile, resulting in the incapability of retrieving any beam parameter from it. The beam was steered out of the target by a vertical steerer upstreams, and the background image was then isolated and recorded (Fig. 8a) to allow its subtraction. Both images (Fig. 7a and Fig. 8a) are the result of the sum of 20 images taken with 10 bunches per macropulse, 0.3 nC per bunch and 2 s exposure time. Figure 9 shows the OTR angular distribution after removing X-rays

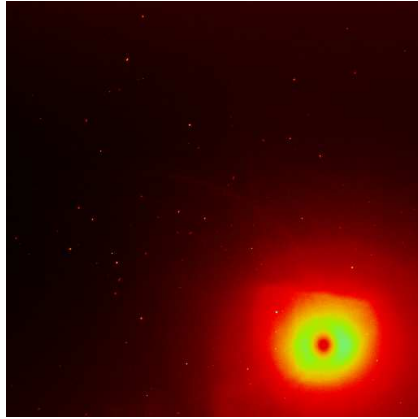

(a) OTR angular distribution

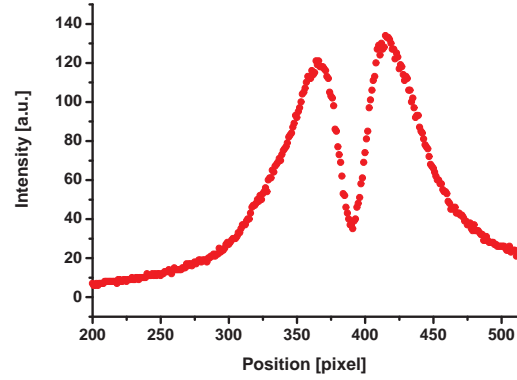

(b) OTR Projection

Figure 6. OTR angular distribution: 1 bunch of 1 nC per macropulse, 1 s exposure time.

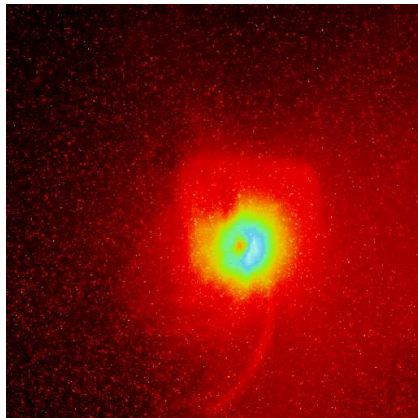

(a) OTR signal and background

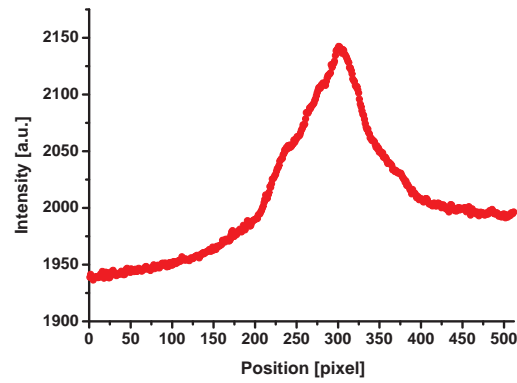

(b) Projection of the OTR signal and background

Figure 7. OTR signal and background and related image profile.

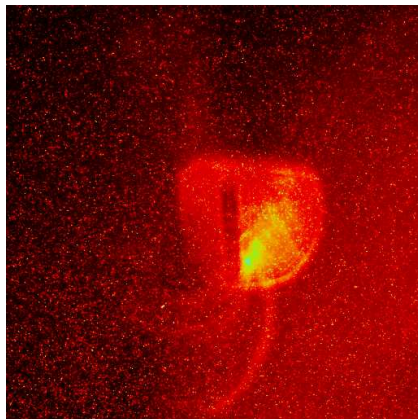

(a) Background image

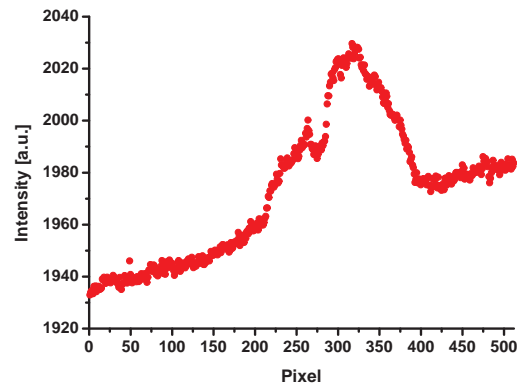

(b) Projection of the background image

Figure 8. Background image and its profile.

and subtracting the background. The result is a clean image whose profile would allow us now to recover beam parameters. This tool becomes mandatory for the analysis of ODR signals (see section 4.4) which, being of the

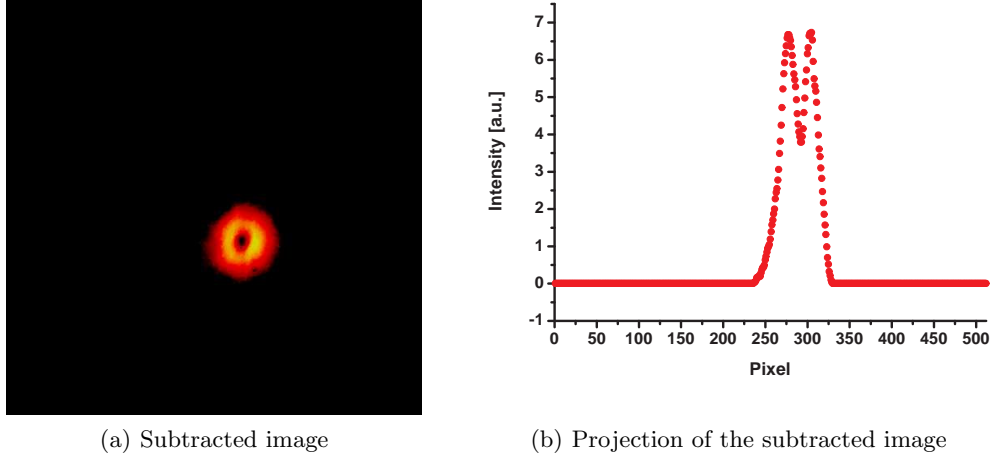

Figure 9. Subtracted image and its profile.

same order of magnitude and even weaker than the background, are covered by it.

4.4. Searching for ODR

The aim of these first measurements was to demonstrate that we are able to detect a difference between OTR and ODR angular distributions. To do so we used a vertical steerer to change the position of the beam on the screen in order to smoothly go from OTR to ODR emission. To detect ODR as well as to distinguish OTR and ODR, high quality electron beam in terms of small transverse emittance, high beam energy and good stability is required. Unfortunately, during the whole set of measurements, the transverse beam size was too large even for the 1 mm slit. To reduce the emittance, i.e. the beam size, the charge was reduced down to 0.3 nC per bunch, and to increase the signal intensity the number of bunches per macropulse was increased to 25. The signal was integrated over 1 s. The nominal beam energy was 620 MeV.

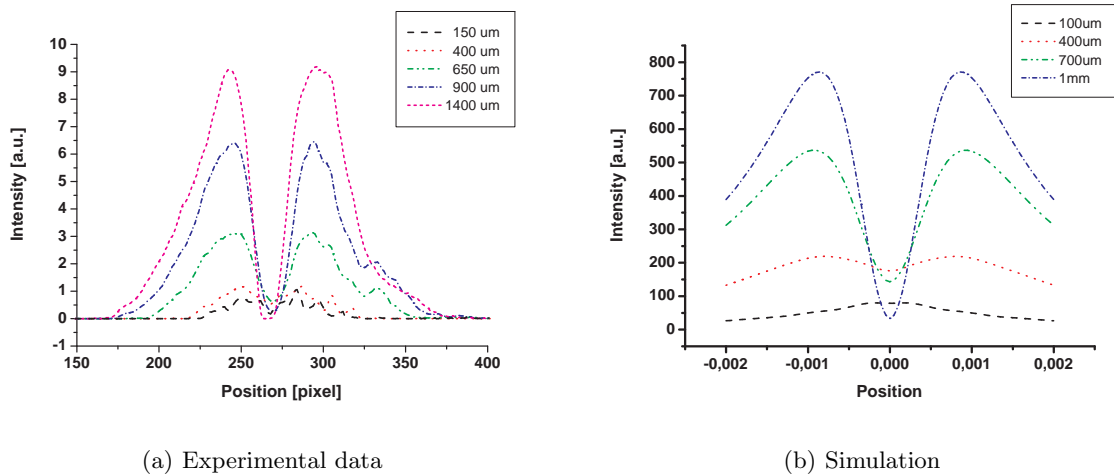

Figure 10. From OTR to ODR: angular distributions for different positions of the beam with respect to the center of the slit. The polarizer is inserted to select the vertical polarization.

The plot in Fig. 10a shows the angular distribution profiles for five steps. The short dash curve (magenta) corresponds to the beam at 1.4 mm from the center of the slit, a condition which gives rise to OTR emission. As the distance decreases the OTR contribution gets lower. The dash curve (black) corresponds to the beam at 150 μm from the center of the slit: ODR emission is now expected, showing a less pronounced minimum in the angular distribution. A simulation (Fig. 10b) reproducing the insertion of the slit shows a qualitative agreement with experimental data. Figure 11 shows the vertical polarized angular distribution for the two limiting cases: a) beam through the slit and b) beam on the OTR screen.

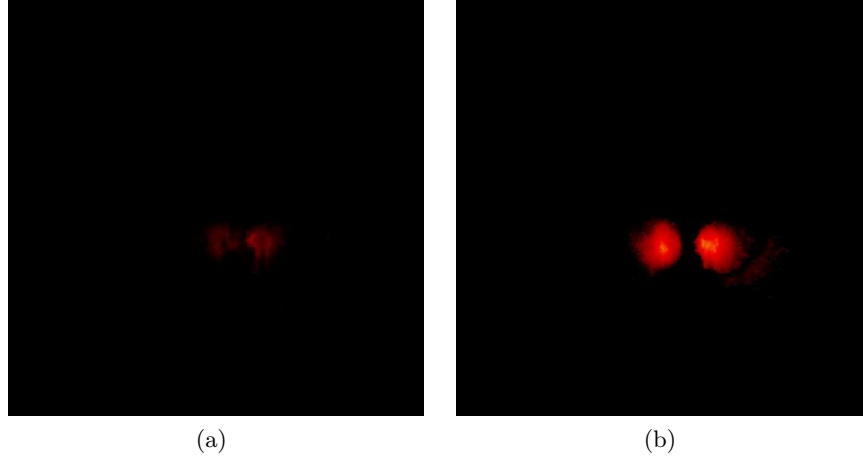

Figure 11. Vertical polarized angular distribution: a) the beam is at 150 μm from the center of the slit (ODR); b) the beam is at 1.4 mm from the center of the slit (OTR).

Only during one of our measurement shifts we succeeded to have the beam shown in Fig. 12a, with an rms size of 190 μm calculated by fitting the beam intensity profile (Fig. 12b) with an asymmetric gaussian distribution. Even in this case, when the beam goes through the slit (Fig. 12c), the tail hit the edges, causing saturation as the intensity increases.

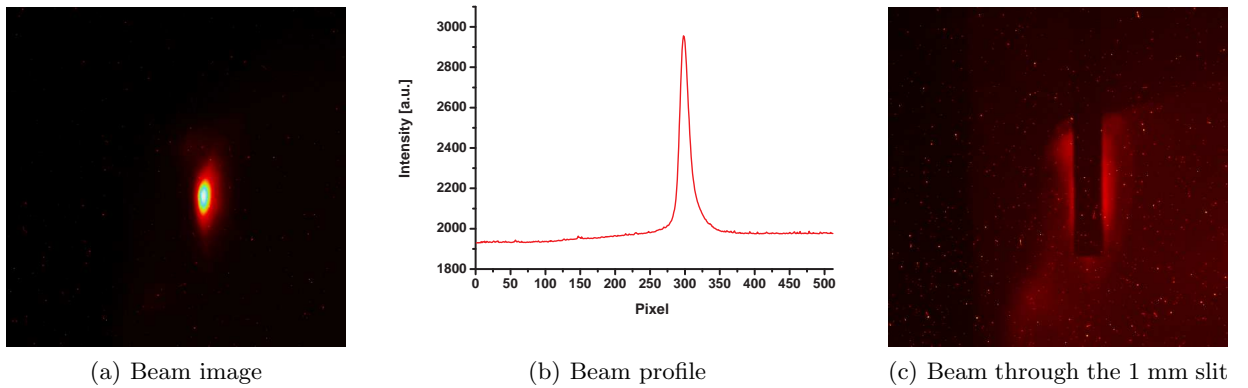

Figure 12. a), b) Image of the beam on the OTR screen and its profile; c) image of the beam through the 1 mm slit: the contribution of the tails is visible.

A measurement dedicated to the ODR detection has been performed with this beam transporting 10 bunches, 0.3 nC per bunch through the center of the 1 mm slit. Several images of both signal and background have been acquired to allow an easier subtraction procedure. The subtracted ODR angular distribution image is shown in Fig. 13a, the corresponding profile is plotted in Fig. 13b (red dots). A simulation which takes into account an

rms beam size of $150 \mu\text{m}$, compatible with the one given from fitting the beam image profile, and zero angular divergence, shows a good qualitative agreement with the measured ODR profile (Fig. 13b, straight line).

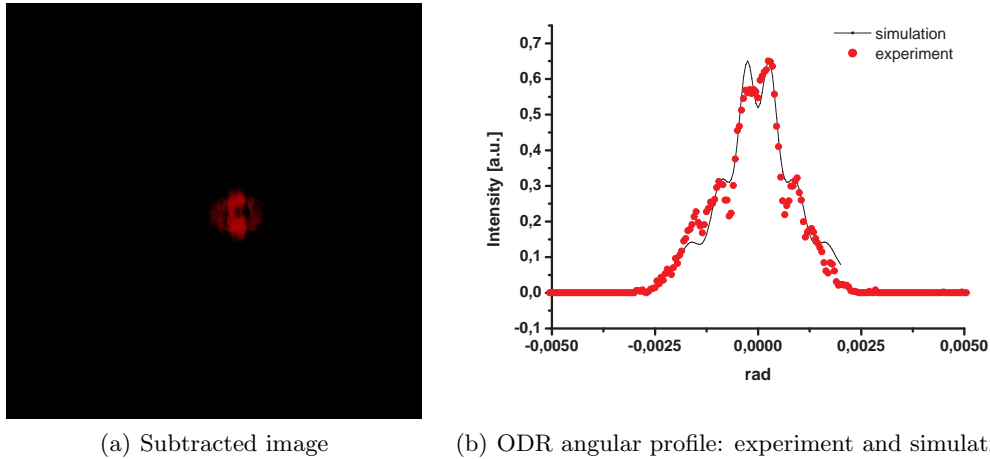

Figure 13. ODR angular distribution: 10 bunches, 0.3 nC per bunch, 1 GeV energy, 1 mm slit, 2 s exposure time. No polarizer is inserted.

5. CONCLUSIONS

The first test of the complete experimental apparatus has been carried out. The presence of unavoidable background together with unoptimal beam conditions made the detection of ODR difficult. However, an off-line LabView tool developed to clean images worked well and allowed us to analyse the experimental data and get first results.

Although these first preliminary measurements did not yet allow us to quantitatively retrieve beam parameters and showed that effort has still be put on improvement of the experimental set-up and background subtraction, they are encouraging and give us confidence to continue the measurements.

6. OUTLOOK

Since FLASH is operated most of the time as a FEL user facility, the beam time for dedicated studies, like our experiment, is limited.

Our next measurements are planned in January 2007 with electron beam energy of 700 MeV, and hopefully with beam conditions allowing us to use the 0.5 mm slit. Before these measurements the experimental set-up will be improved: during FLASH maintenance period in October 2006, a second target, a replica of the first one, will be installed. The second target will be used during preliminary adjustment of the beam to avoid damages on the slit used for measurements. In order to reduce synchrotron light several ideas are under studies. The whole system will be realigned as well. In order to reduce contribution from X-rays, a better shielding of the camera is foreseen. Also an update of the analysis software is planned.

In spring 2007 an additional accelerating module will be installed to FLASH increasing the electron beam energy up to 1 GeV. Our last measurements period is planned in Autumn 2007 with beam energy of 1 GeV. This, together with improved experimental set-up, should allow a clear ODR detection.

7. ACKNOWLEDGEMENT

We thank DESY and FLASH team for the opportunity to perform our experiment. Special thanks are to FLASH shift crews for tuning the linac for beam conditions required for the experiment. We thank also R.Sorchetti and L.Cacciotti (INFN-LNF) for their fundamental technical assistance and B.Polzin (DESY) for his support on control system issues.

REFERENCES

1. M. Castellano, "A new non-intercepting beam size diagnostics using diffraction radiation from a slit," *Nucl. Instr. and Meth. in Phys. Res.* **A394**, p. 275, 1997.
2. P. Karataev et al., "Beam size measurement with optical diffraction radiation at KEK Accelerator Test Facility," *Phys. Rev. Lett.* **93**, p. 244802, 2004.
3. S. Araki et al., "Optical diffraction radiation beam size monitor at KEK accelerator test facility," in *Channeling 2006 proceedings*, 2006.
4. M. Ter-Mikaelian, *High-Energy Electromagnetic Processes in Condensed Media*, Wiley-Interscience.