

Beam tail measurements by wire scanners

By Kay Wittenburg,
Deutsches Elektronen Synchrotron DESY, Hamburg, Germany

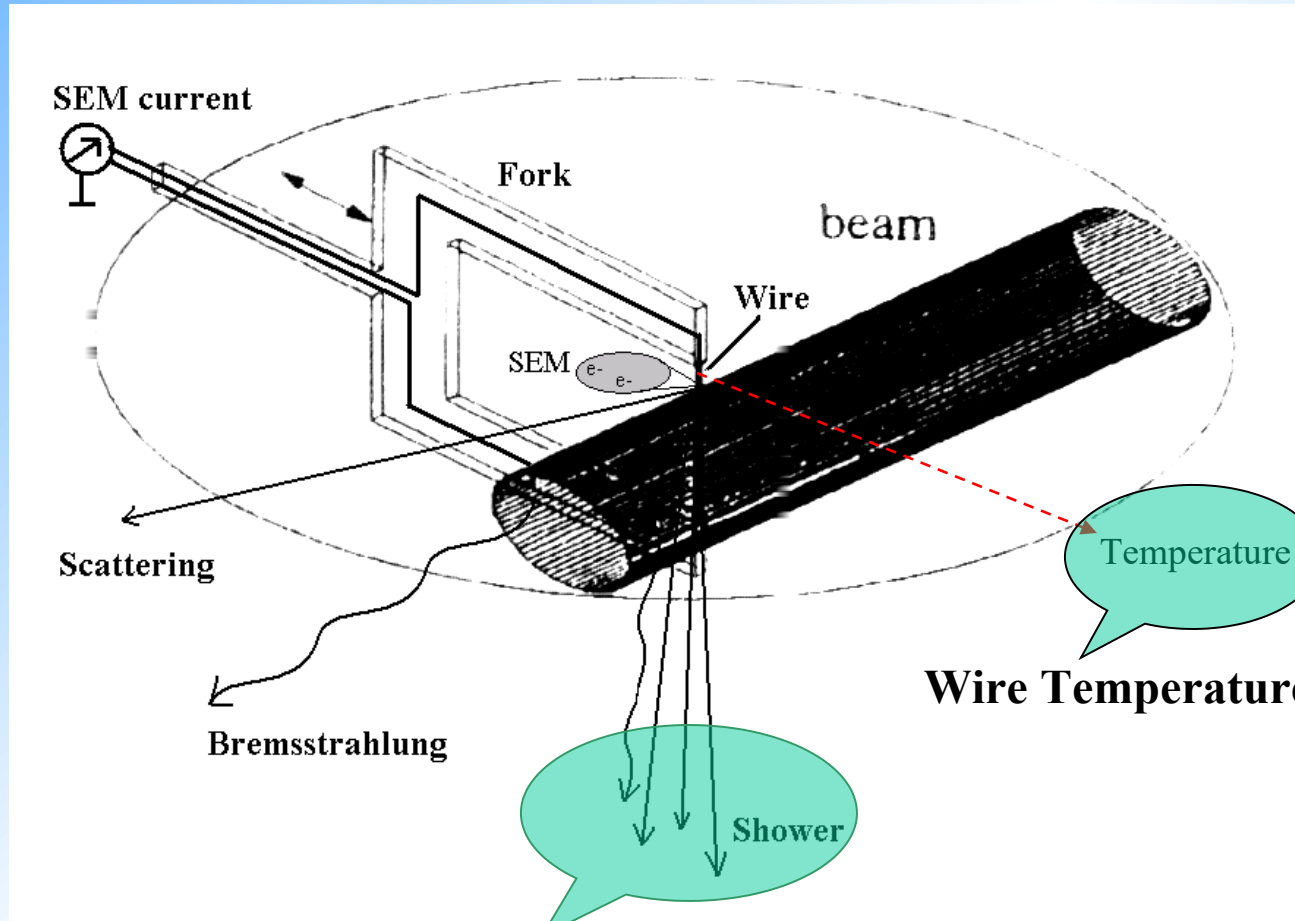

Counting bunch by bunch

HERA at 920 GeV/c

Deposited energy in the counter = $5.3 \cdot 10^{-7}$ GeV/p.
 The efficiency of the counter is less than 2%.
 The photon yield in the frequency range of PM is ≈ 1 photon per 100eV of ionization energy loss,
 typical efficiency of PM cathode ≈ 0.1 , **hence the expected signal is $1.1 \cdot 10^{-2}$ photoelectrons per proton intersecting the wire area.**

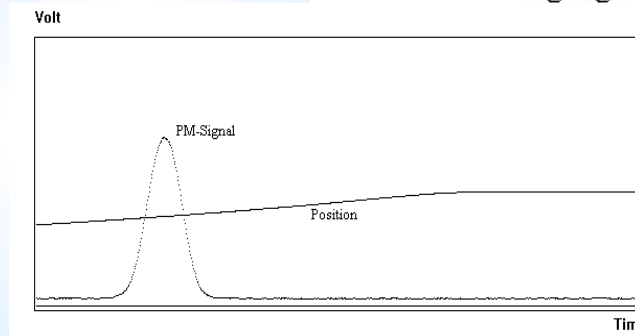
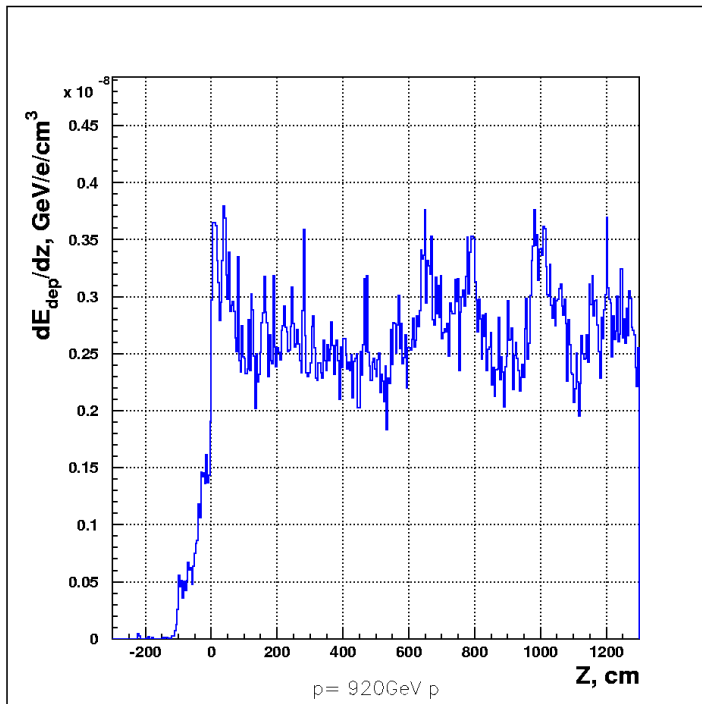
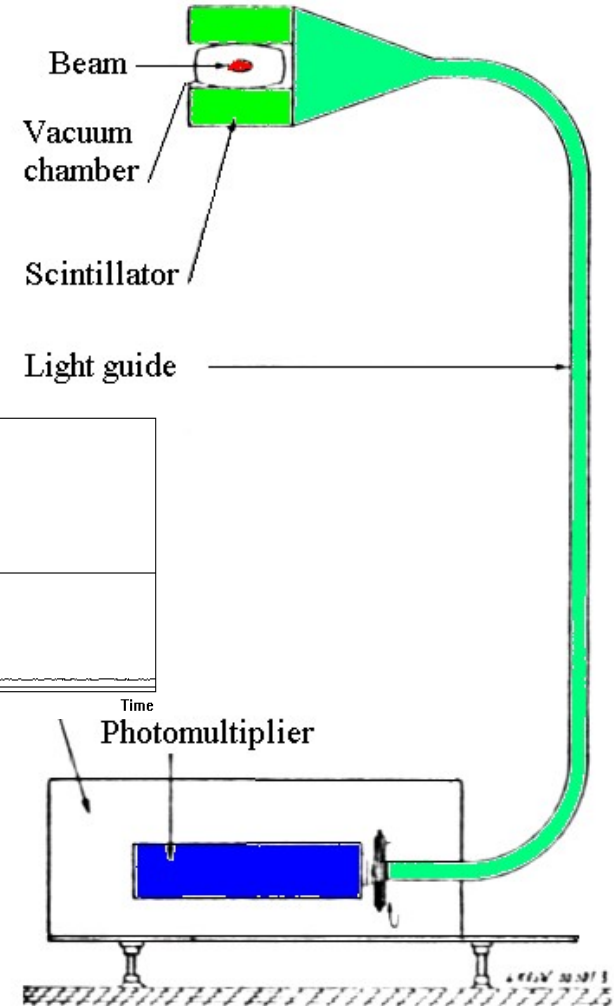

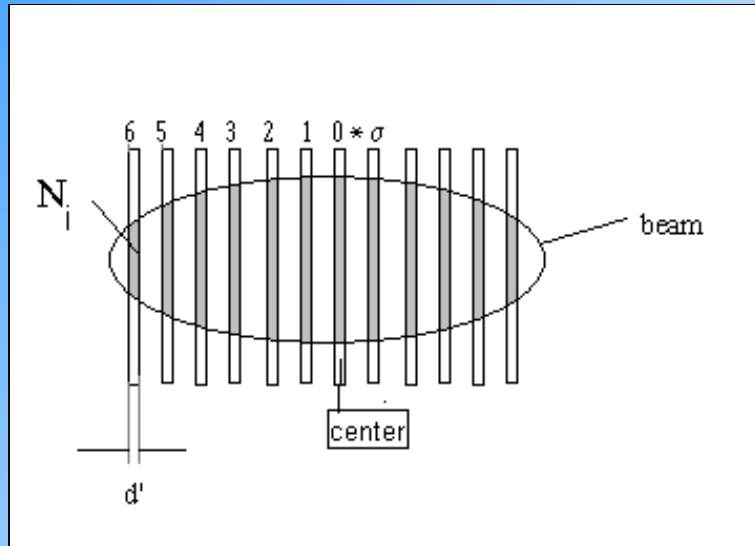

$$N_i = n_{bunch} \cdot \int_{i \cdot \sigma - \frac{d'}{2}}^{i \cdot \sigma + \frac{d'}{2}} \frac{1}{\sigma_h \cdot \sqrt{2 \cdot \pi}} \cdot \exp\left(\frac{-x^2}{2 \cdot \sigma_h^2}\right) dx$$

N = protons intersecting wire area

σ = beam width (0.7 mm)

d' = wire diameter (7 μm)

$N_{bunch} = 10^{11}$ protons

Bunch Rate = 1/96 ns = 10.4 MHz

Assume signal efficiency of 10^{-6}

N_i	Position	Eff _i	Rate [Signals/bunch]
$3.989 \cdot 10^8$	Center	398.941	
$2.42 \cdot 10^8$	1 σ	241.971	
$5.399 \cdot 10^7$	2 σ	53.992	
$4.432 \cdot 10^6$...	4.432	
$1.338 \cdot 10^5$		0.134	
$1.487 \cdot 10^3$		0.001	
6.077		$6.077 \cdot 10^{-6}$	
0.009		$9.137 \cdot 10^{-9}$	
$5.054 \cdot 10^{-6}$		$5.054 \cdot 10^{-12}$	
$1.028 \cdot 10^{-9}$		$1.028 \cdot 10^{-15}$	
$7.698 \cdot 10^{-14}$		0	

Saturation





Black body radiation: The temperature T_{bb} at which the radiated power is equal to the deposited energy in the wire P_{dep} [MeV/s] can be calculated from the Stefan-Boltzmann-law:

$$T_{bb} = \sqrt[4]{\frac{P_{dep}}{s \cdot A}} \quad [K]$$

where $s = 35.4 \text{ MeV} / (\text{s}^1 \text{ cm}^2 \text{ } ^0\text{K}^4)$ is the Stefan-Boltzmann-constant and A is the area of radiating surface. The surface of the heated wire portion A is approx $2 \cdot \sigma_{v,h} \cdot d \cdot \pi [\text{cm}^2]$. The power can be calculated by:

$$P_{dep,i} = \alpha \cdot N_i \cdot dE / dx \cdot d' \cdot f_{bunch} \quad [MeV / s]$$

α is the expected loss from secondaries = 0.3
 $dE/dx = 4.1 \text{ MeV/cm}$ (carbon)

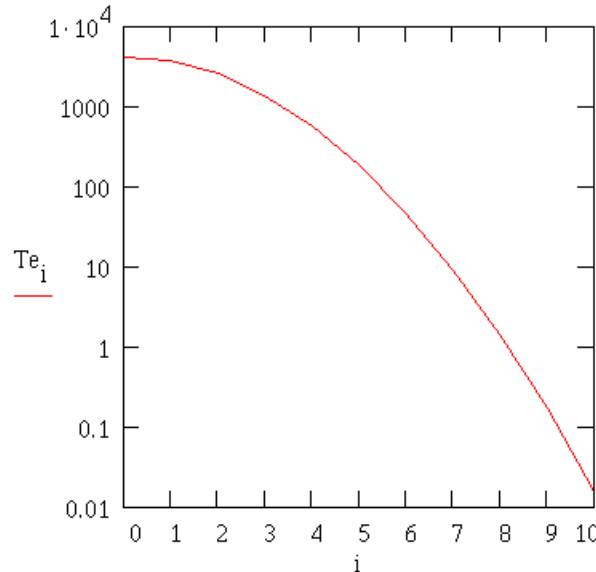

Te_i	Position
$4.257 \cdot 10^3$	Center
$3.756 \cdot 10^3$	1σ
$2.582 \cdot 10^3$	2σ
$1.382 \cdot 10^3$...
576.081	
187.028	
47.289	
9.312	
1.428	
0.171	
0.016	

$T_{melt} = 3000 \text{ } ^\circ\text{C}$

For wire temperature measurement is proposed to use the strong dependence of frequency of normal oscillations of tensioned wire on temperature. Excitation can be a parametric resonant mechanism generated by special piezoelectric transducers. Oscillations can be detected by piezoelectric or optical ways and can also serve as source of beam profile information. The temperature sensitivity of the vibrating wire sensor estimated on the level $10^{-4} \text{ }^\circ\text{C}$.

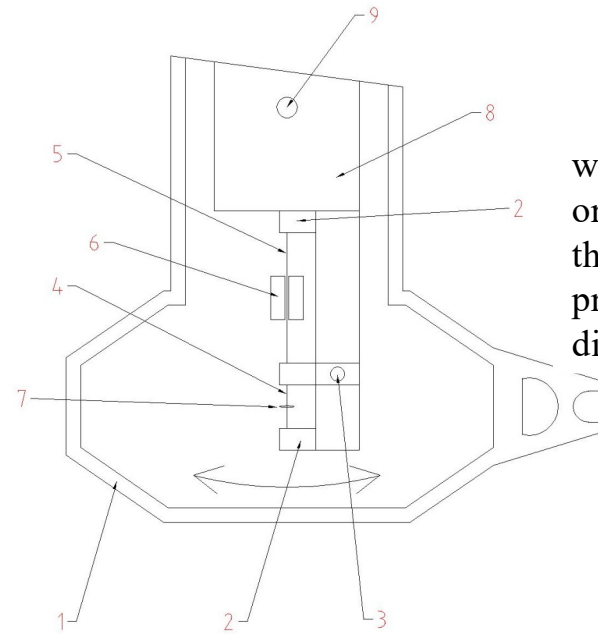

wire oscillation orientation along the beam propagation direction

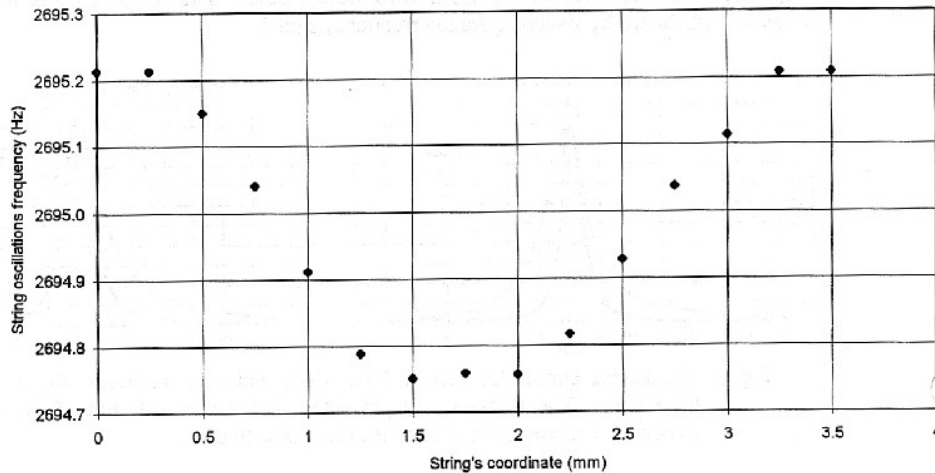
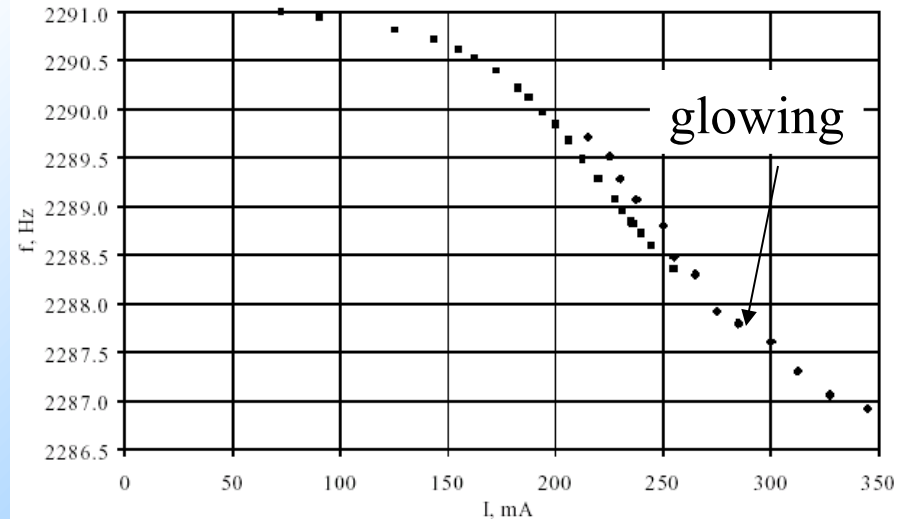

Fig 3. Laser beam scanning by vibrating wire.



Frequency dependence on current in a $70 \mu\text{m}$ tungsten wire

Vibrating wire scanner: first experimental results on the injector beam of Yerevan synchrotron

Arutunian S.G., Dobrovolski N.M., Mailian M.R., Vasiniuk I.E.

Yerevan Physics Institute



The first experimental results of the transversal scanning of the injector electron beam (6 nA after collimation) of Yerevan synchrotron by scanner based on the vibrating wire (vibrating wire scanner - VWS) are presented and the corresponding horizontal beam profiles are obtained. The information from the beam local intensity is picked up from the measuring of wire natural oscillations depending on wire temperature.

vibrating wire: 90 μm beryl-bronze wire

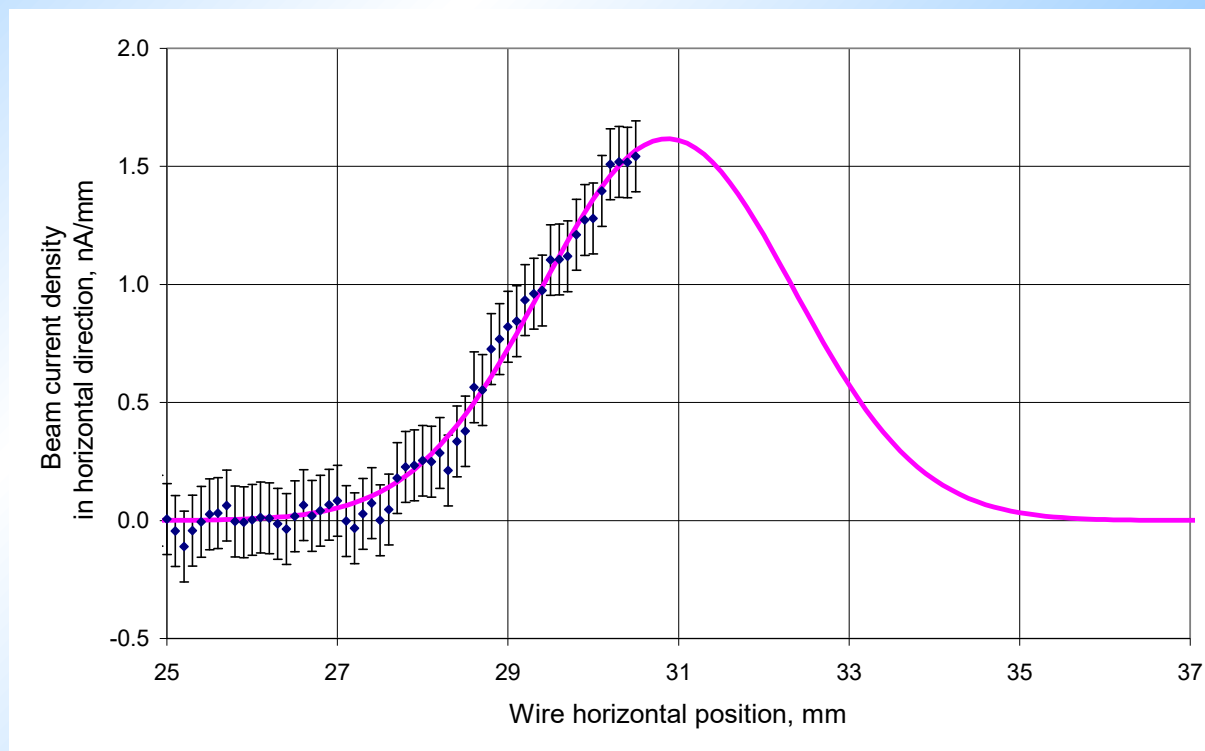

The overall current of the beam is set $I_0 = 6$ nA. Because of short traveling distance only half of the beam was scanned.

Counting Mode

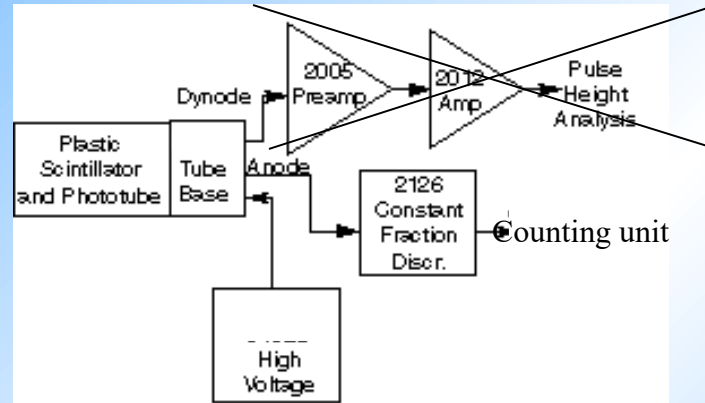
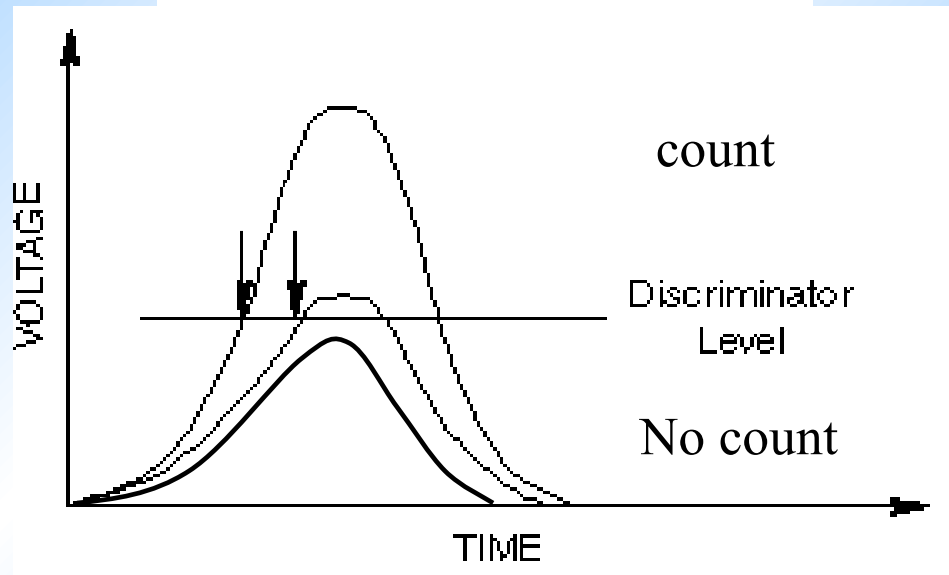

Figure 1.8: Plastic Scintillation Detector Electronics



HERA-B Detector

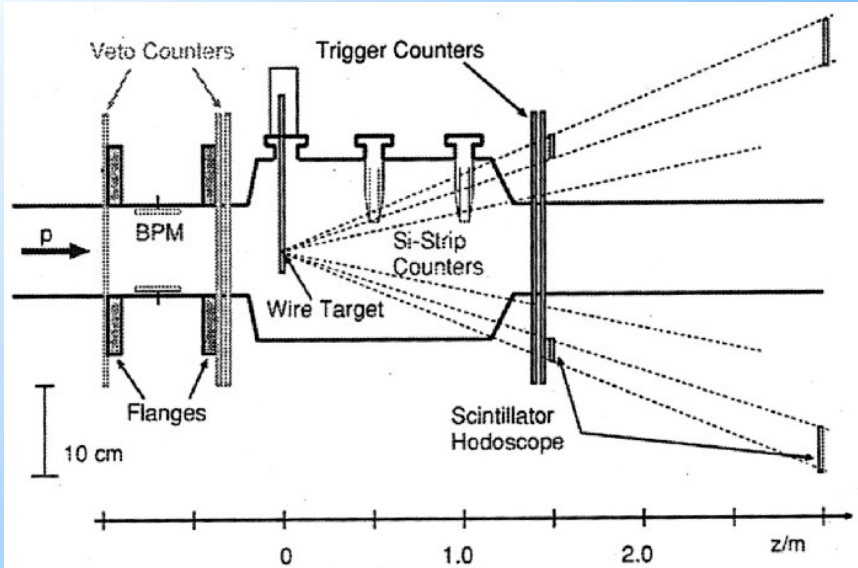
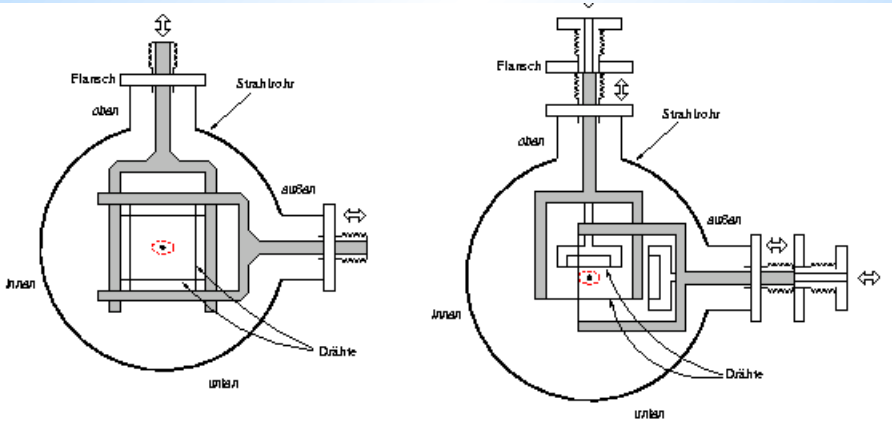
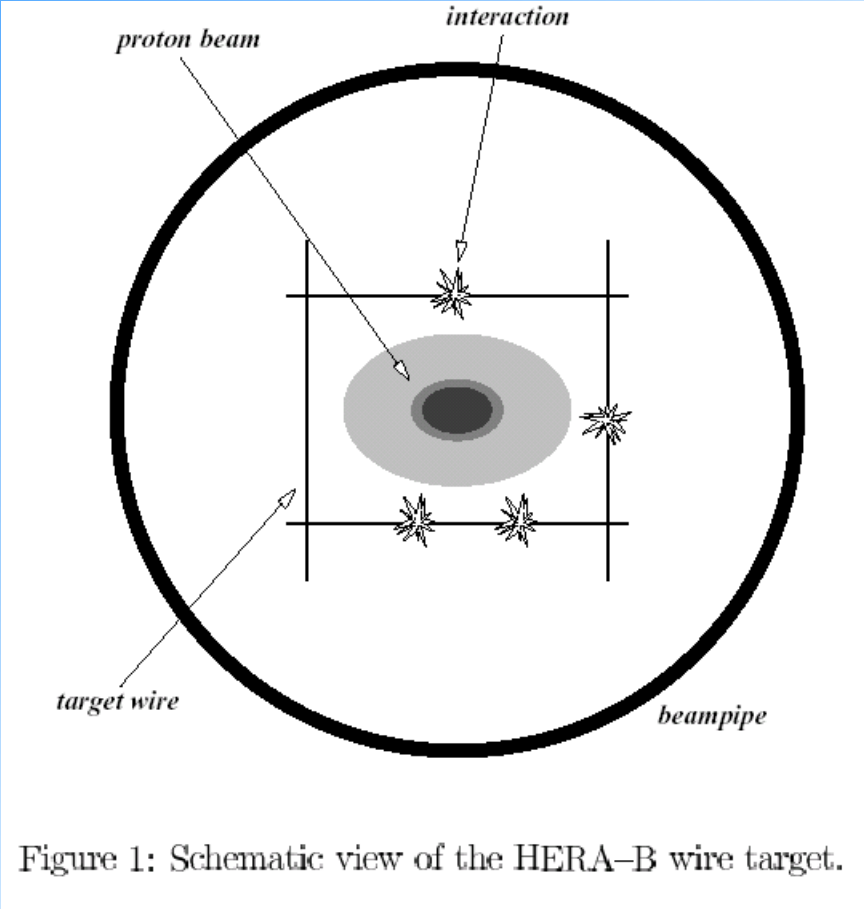
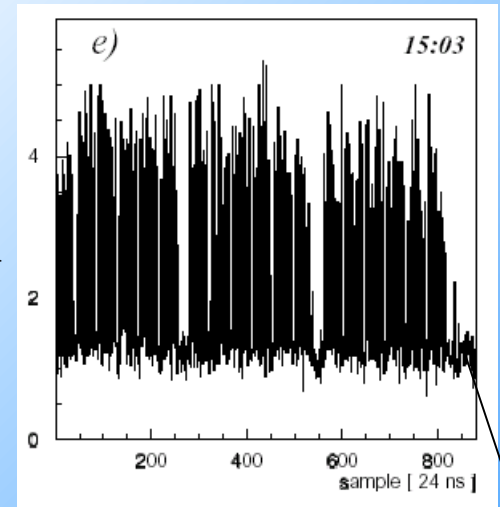
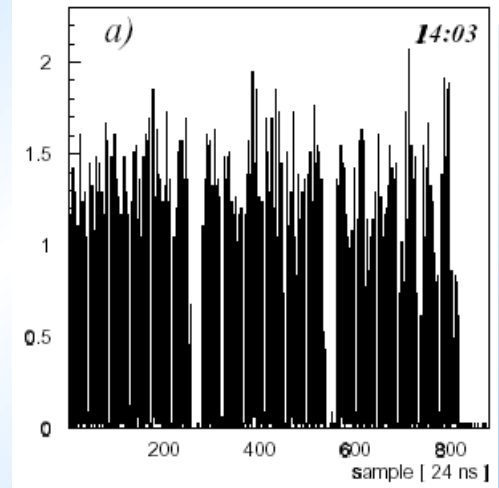
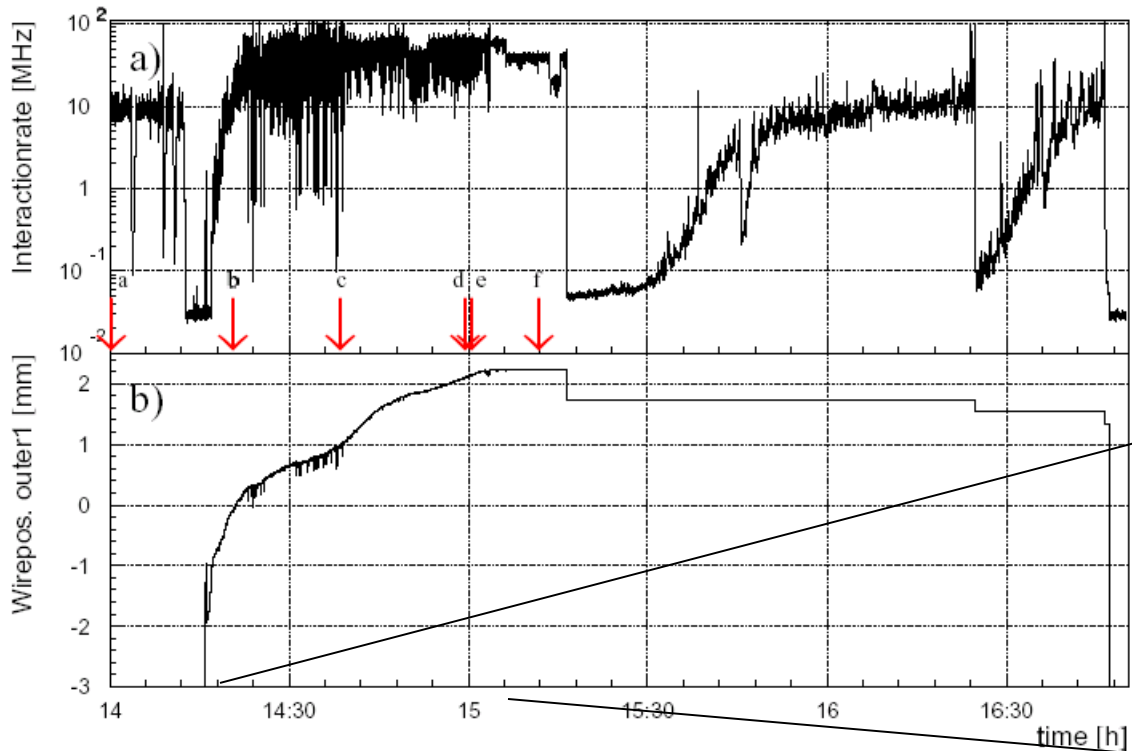

Figure 1: Schematic view of the HERA-B wire target.

Detection efficiency > 50%

Detection of coasting beam



Note the increased rate in the Bunch gaps (=coasting beam)

Another method:

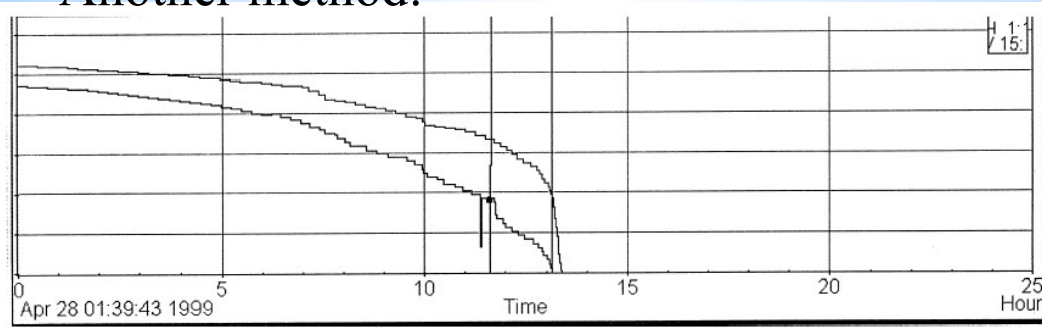

Total DC current (upper) and total bunch current (lower)

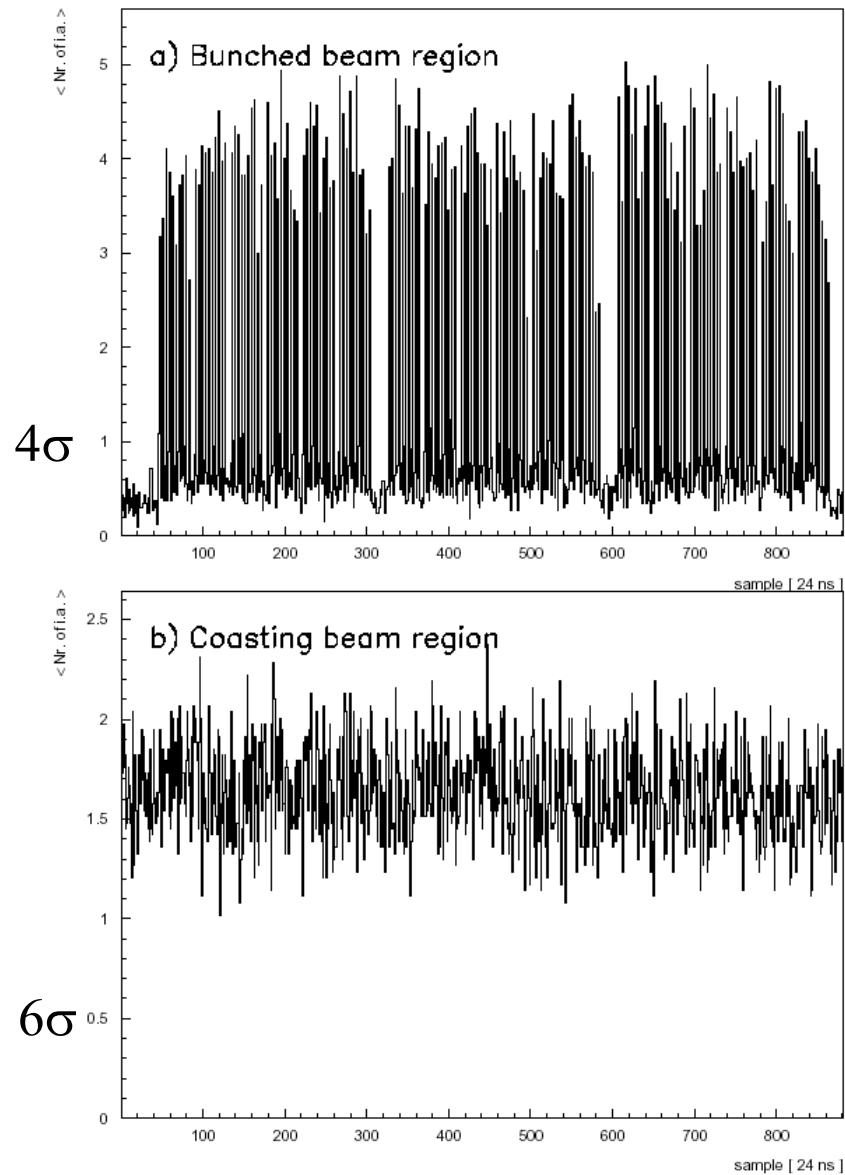
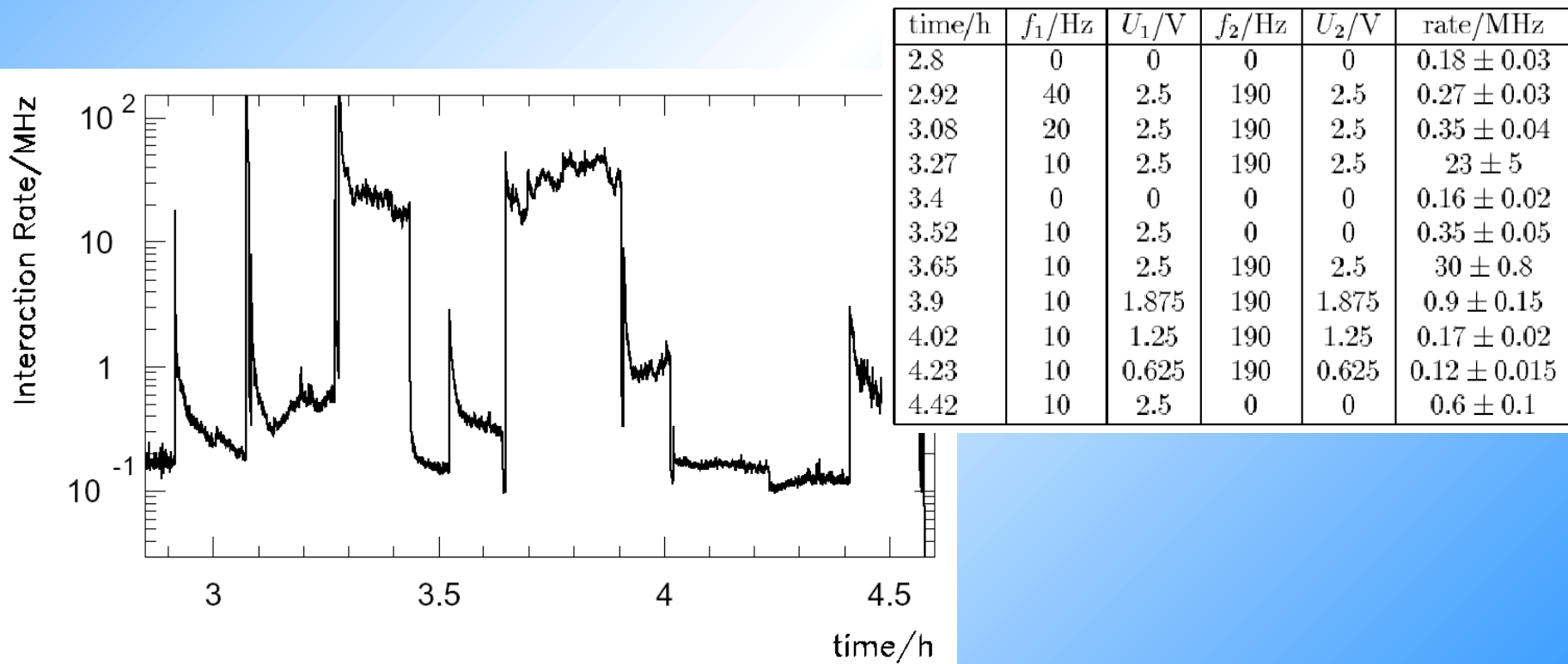

Figure 11.2: The time structure of the proton interaction for an outer target wire at different distances of the wire to the beam center: a) wire $\approx 4\sigma$ from the beam center and b) wire $\geq 6\sigma$ from the beam center.

The negative horizontal dispersion leads to signals on the outside wires

The HERA-B experiment [43] uses an internal wire target inserted into the halo of the stored HERA proton beam. While machine performance was improved during recent years, this halo practically vanished. Therefore the wire target has to be moved close to the beam core at about 3 to 4σ in order to keep the actual rate constant at the design rate of five interactions per bunch crossing. As it was observed, this leads to a high sensitivity of the interaction rate to beam orbit jitter of very small amplitudes. To overcome this situation, it has been suggested to artificially create some beam halo by means of tune modulation [42].



Neighbor-buckets

Abbildung 5.3: Das TDC-Spektrum beim Betrieb eines äußeren Drahttargets zeigt die zeitliche Zuordnung der Wechselwirkungen innerhalb eines Zeitraums von 202 ns bei einer zeitlichen Auflösung von 0,1 ns. Wechselwirkungen von Protonen zwischen den gefüllten Bunchen sind wie in Abbildung 5.2 beim Betrieb eines äußeren Targetdrahtes auch in den Daten des TDC-Systems zu sehen.

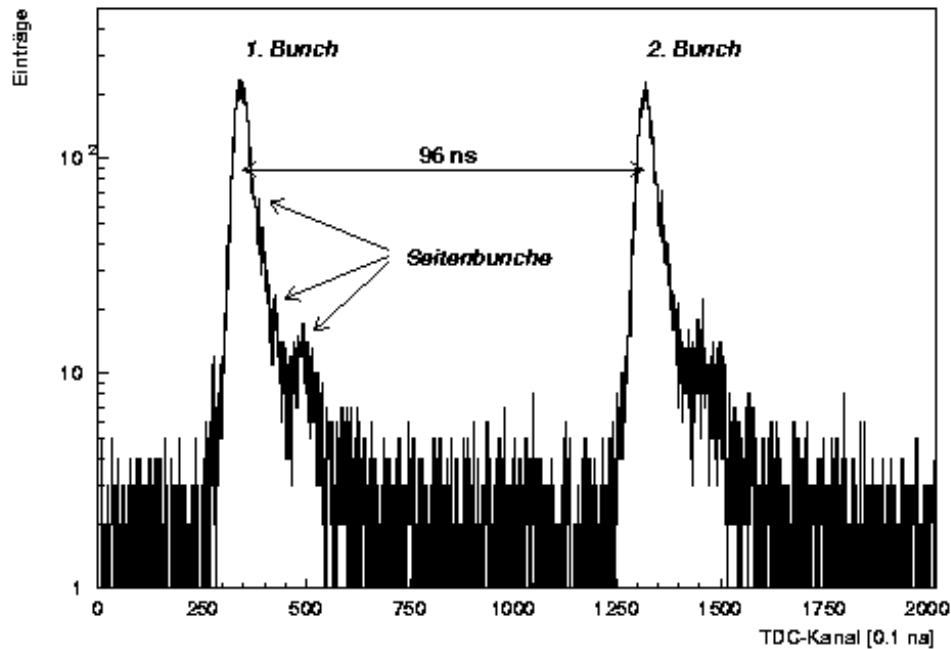

Another method: Fast wall current monitor

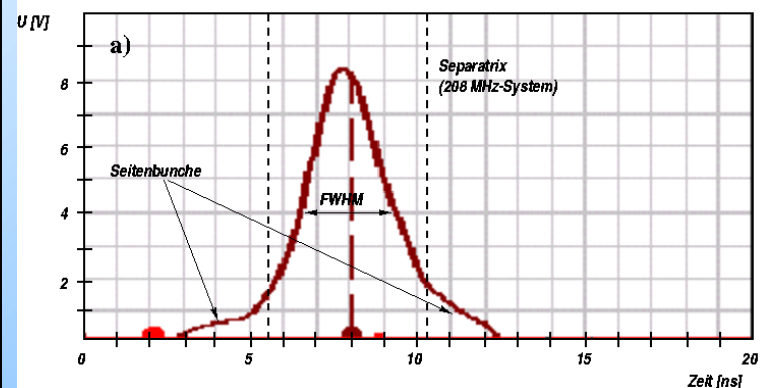

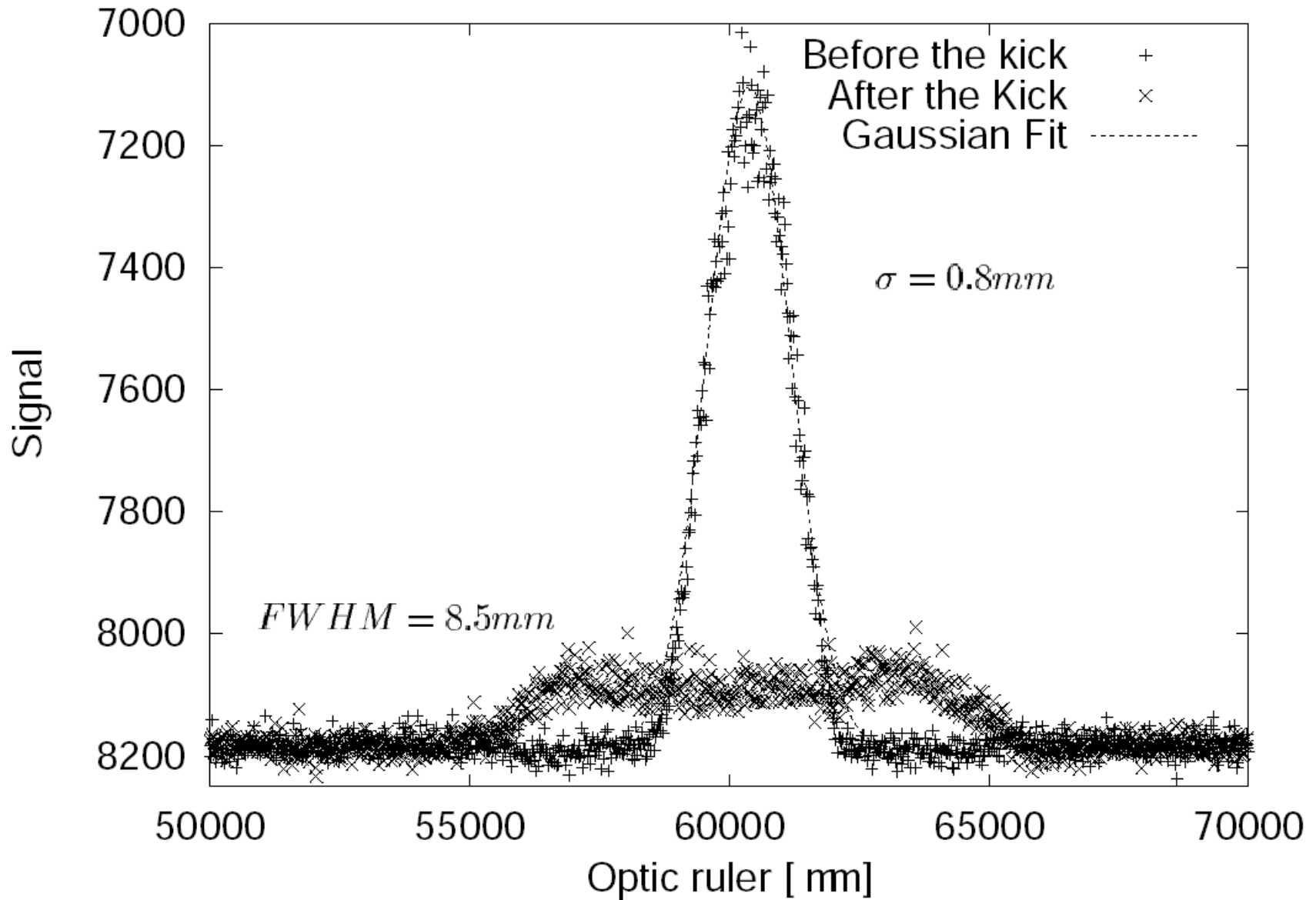



References

PHYSICAL REVIEW SPECIAL TOPICS - ACCELERATORS AND BEAMS, VOLUME 2, 122801 (1999)

Vibrating wire for beam profile scanning

S. G. Arutunian, N. M. Dobrovolski, M. R. Mailian, I. G. Sinenko, and I. E. Vasiniuk

Yerevan Physics Institute, Alikhanian Brothers Street 2, 375036, Yerevan, Armenia

(Received 4 March 1999; published 9 December 1999)

Proceedings of the 1999 Particle Accelerator Conference, York, 1999

MAGNETIC FIELD DISTRIBUTION MEASUREMENT BY

VIBRATING WIRE STRAIN GAUGE

Arutunian S.G., Dobrovolski N.M., Egiazarian S.L.,

Mailian M.R., Sinenko I.G., Sinjavski A.V., Vasiniuk I.E.

Problems of Installation of Vibrating Wire Scanners into Accelerator Vacuum Chamber

S. Arutunian, A. Avetisyan, N. Dobrovolski, M. Mayilyan, I. Vasiniuk, YerPhI, Yerevan;

K. Wittenburg, DESY, Hamburg; R. Reetz, HTM Reetz GmbH, Berlin

Proc. Eighth European Particle Accelerator Conference

La Villette – PARIS, 3 - 7 June 2002

HERA Accelerator studies 1999 2000

DESY HERA 00-02, DESY-HERA 00-07

Observation of coasting beam at the HERA proton-ring

K. Ehret et al.,

Nuclear Instruments and Methods in Physics Research A 456 (2001) 206}216