

Estimation of the signal from the wire scanner in the TTF

By Sergei Striganov, IHEP
Gerald Schmidt and Kay Wittenburg, DESY
April, 1999

Introduction

The Tesla Test Facility (TTF) is a 500 MeV superconducting linear test accelerator to study the technical basics for a future 500 GeV e^+e^- linear collider. Additionally, an undulator for a SASE FEL (free electron laser operating in the vacuum ultraviolet) will be installed and operating with an electron beam energy between 200 and 500 MeV to produce VUV radiation..

Ref. 1 had proposed to use wire scanners in the TTF for emittance measurements. The main task of the wire scanners will be to determine very precisely the absolute ($\approx 20 \mu\text{m}$) and relative ($\approx 1 \mu\text{m}$) beam position in the FEL region [Ref. 2]. Four pairs of scanners at four different locations are foreseen to measure the position of the beam as well as its profile (emittance). The scanners are located each 4.8 m in between the FEL undulator sections. The wire scanners are mounted horizontally and vertically on a so-called diagnostic block, which houses also a non-destructive cavity monitor. This cavity monitor will be calibrated by means of the wire scanners and allows then a non-destructive absolute beam position measurement. There are three possible readout schemes of the signal from the scanners: 1) Scattered particles crossing a scintillator close to the scanner, 2) Bremsstrahlung-photons hitting a downstream detector, 3) current in the wire created by secondary emission. In this report we studied the signal one can expect from this three methodes.

The following basic TTF parameters are assumed:

Parameter:	TTF FEL	TTF
Beam width at the scanner (x, y): σ	50 μm	150 μm
Charge/bunch	1 nC	8 nC
Number of electrons/bunch: N_b	$6.25 \cdot 10^9$	$5.0 \cdot 10^{10}$
Bunch repetition frequency: F_b	9 MHz	1 MHz
Length of the macro pulse: L	800 μs	800 μs
Max. macropulse rep. rate: F_p	10 Hz	10 Hz
Number of electrons/macro pulse: N_p	$4.5 \cdot 10^{13}$	$4.0 \cdot 10^{13}$

Simulations

Since there is no experience with wire scanners at low energy electron accelerators, we have studied the signal from the wire scanner at TTF by use of Monte Carlo simulations (GEANT3.21, Ref. 3). In the following calculations, the energy of the primary electrons was 200 MeV for all calculations. The results can be scaled with reasonable accuracy to other beam energies. The diameter of the wire was assumed to be $d = 7 \mu\text{m}$. The geometry (radial symmetric) simulated in the program is shown in Fig. 1. It is the same for all locations of the wire scanners. The wire was in the middle of the beam pipe, at a distance of 5.7 cm from the upper end of a 15.4 x 18.5 cm iron block (ABS1). The detector was a scintillator paddle (VDE1) behind the iron block, close to and around the beam pipe. Its thickness is 1 cm and the diameter is the same as the one of the iron block (15.4 / 2 cm). A drawing of the real geometry is shown in Fig. 2.

The electrons of the beam will undergo mainly scattering processes if hitting the wire. This results in three possible methods to measure the signal:

- 1) Some of the scattered electrons will hit the beam pipe and will create a shower. The intensity of the shower can be detected with a scintillator counter (scintillator + photomultiplier readout) downstream and can be plotted versus the position of the wire to receive the required information.
- 2) The scattered electrons will create Bremsstrahlung at the wire. The Bremsstrahlung-photons have a small opening angle and can be detected on axis some meters downstream, behind a horizontal bending magnet which separates the electron beam from the Bremsstrahlungs-photons. The hard photons from

the Bremsstrahlung will be detected by a fully absorbing shower counter like lead glass or BGO ($\text{Bi}_4\text{Ge}_3\text{O}_{12}$). A mirrors reflects the visible photons from the FEL to other experiments and let the harder Bremsstrahlung-photons pass. The intensity can be plotted versus the position of the wire.

- 3) A third measurement uses the secondary emission of the wire. The current in the wire, as a result of this process, will be measured versus the wire position. The signal can be estimated by use of the secondary emission coefficient, which is known to be around 3% for the carbon wire. The signal is estimated in chapter: "Secondary emission Signal".

Three different materials were studied: 1) Carbon (C); $\rho = 2.265 \text{ g/cm}^3$, 2) Quartz (SiO_2); $\rho = 2.2 \text{ g/cm}^3$, 3) Ceramic (Al_2O_3); $\rho = 3.97 \text{ g/cm}^3$. The secondary emission mode cannot work for 2) and 3) because these are isolating materials. These materials (2, 3) are tested and used in LEP and found to be resistant to higher order mode pickup which may damage (melt) conducting wire material¹.

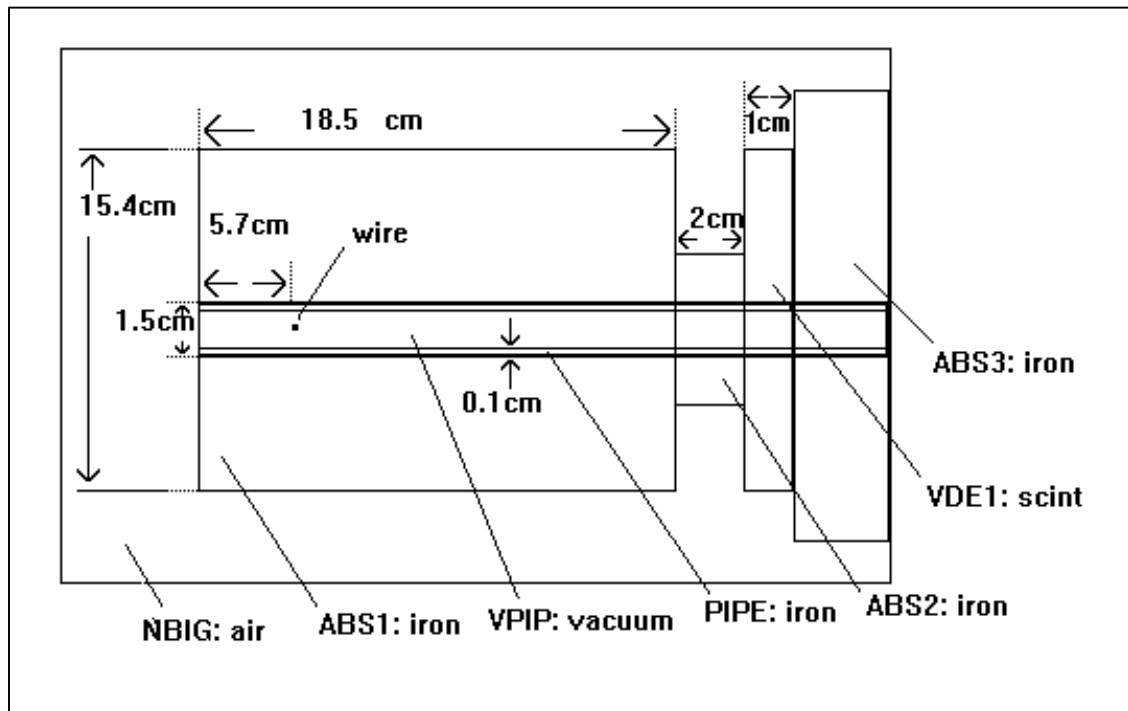

Fig. 1: Sketch of the Geometry used in the Monte Carlo Program

¹ An other material (SiC) is under study at CERN with some good results

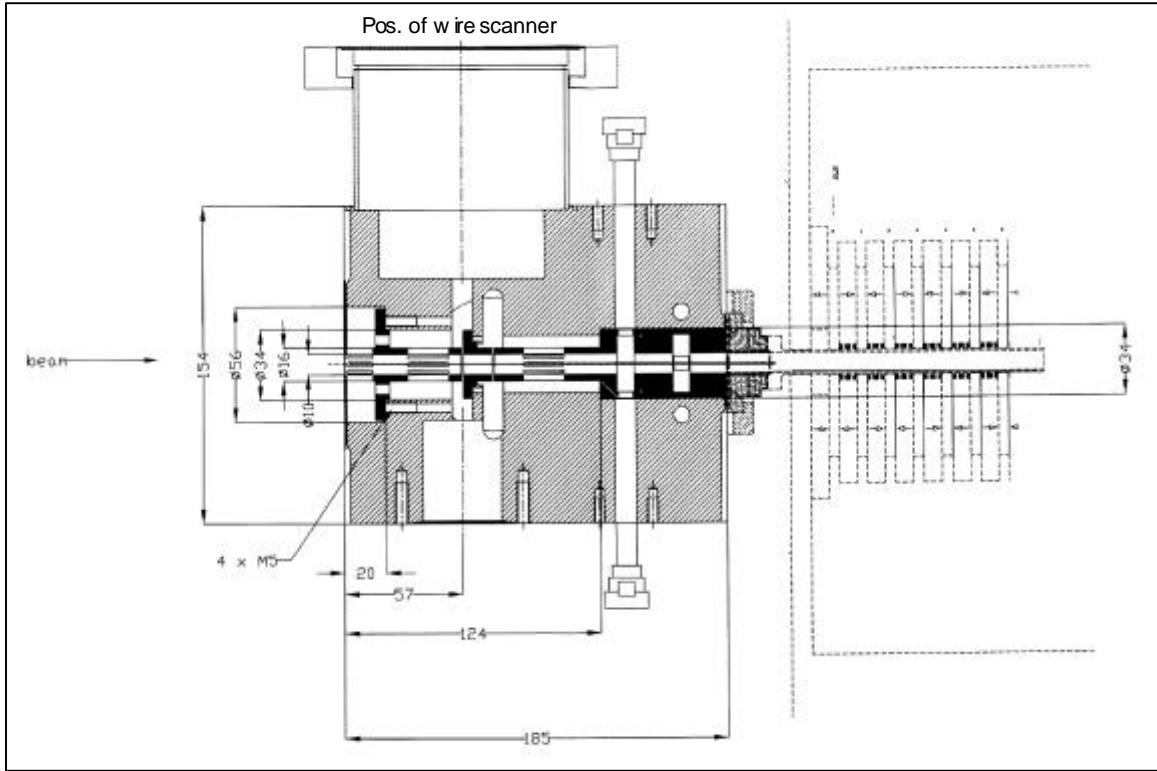

Fig. 2: Drawing of the real geometry (diagnostic block) at the wire scanner location

A) Simulation results for the scintillator measurements

The results are based on 10^7 primary electrons hitting the center of the wire. The deposited energy E_{dep} in the scintillator was summed over all events and is shown in the Table 1.

Wire material	E_{dep} deposited energy/ $10^7 e^-$	entries in the scintillator
Carbon	528 MeV	224
Quartz	804 MeV	389
Ceramic	1178 MeV	604

Table 1

Fig. 4 shows the energy histogram for the entries. The integration over the entries gives E_{dep} . Note that all the entries will happen at the same time, so that the response of the scintillator will be proportional to E_{dep} . One bunch of the TTF will have about $1 \text{ nC} = 6.25 \cdot 10^9 e^- = N_b$ and a width of $\sigma = 50 \mu\text{m}$. Assuming a mean wire diameter of $d_1 = d \cdot \pi/4$, a part r of the electrons will hit the wire.

$$r := \int_{-\frac{d_1}{2} + n \cdot s}^{\frac{d_1}{2} + n \cdot s} \frac{1}{s \cdot \sqrt{2 \cdot \pi}} \cdot \exp\left[-\frac{(x)^2}{2 \cdot s^2}\right] dx$$

with $s = \text{beam width } \sigma$ and $n \in \mathbb{R}$

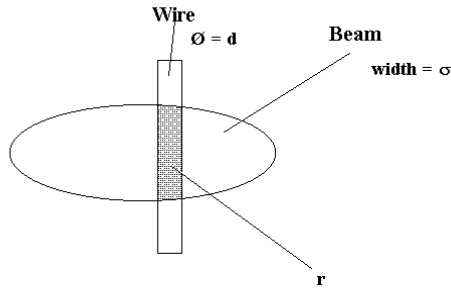

Fig. 3: Illustration of the part (r) of the electrons hitting the wire

Position of wire	Electrons hitting wire	Signal/bunch Carbon	Signal /bunch Quartz	Signal/bunch Ceramic
center	$2.75 \cdot 10^8$	14520 MeV	22110 MeV	32395 MeV
1 s	$1.69 \cdot 10^8$	8923 MeV	13587 MeV	19908 MeV
2 s	$0.375 \cdot 10^8$	1980 MeV	3015 MeV	4418 MeV
3 s	$0.031 \cdot 10^8$	164 MeV	250 MeV	366 MeV

Table 2

The minimum deposited energy, which is detectable by the scintillation counter, is less than 10 MeV. Therefore all wire materials will succeed the requirements in the TTF in view of their signal response, even with an electron beam charge of less than 1/10 of the design current. The position of the scintillator just behind the iron block is adequate. Fig. 5 shows the radial distribution of the shower particles in the scintillator. The main part of the particles reaches the scintillator near the beam pipe. But a significant part hit it at a bigger radius. Therefore the scintillator should be positioned as close as possible to the beam pipe and should cover a large fraction of the solid angle.

Fig. 6 shows the number of entries of scattered electrons along the vacuum pipe. It has a maximum at about 6 m behind the scanner, which is about 10 times bigger than 20 cm behind the scanner. Therefore the scintillator of the following scanner may receive a signal, too. The signal might be bigger than the one from the adjacent scintillator. But note that we didn't include in this calculation all the surrounding parts like magnets etc., which certainly will reduce the signal at the second scintillator.

Entries

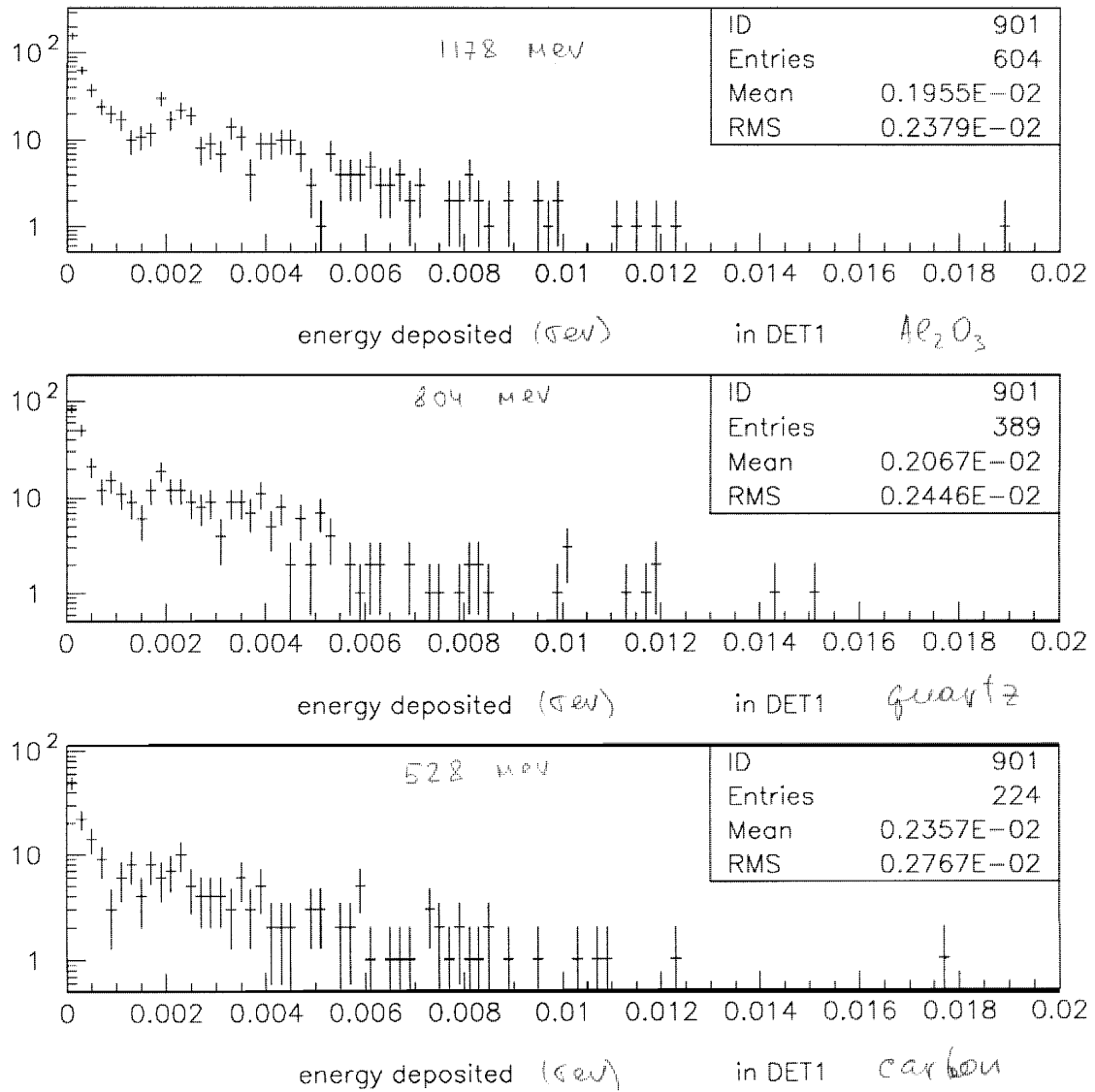

Fig. 4: Histogram of the deposited energy in the scintillator

Entries

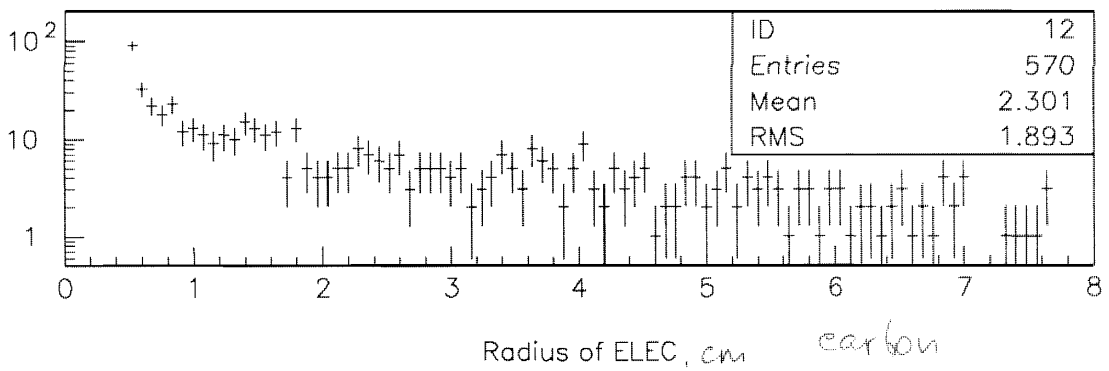
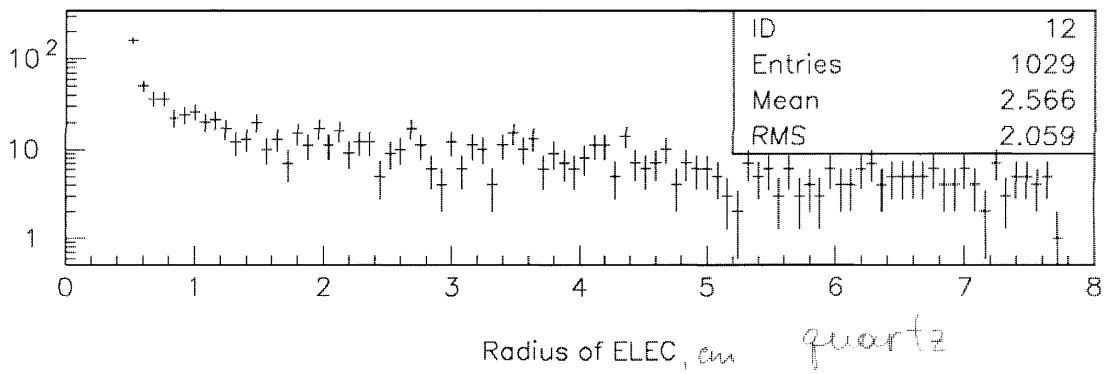
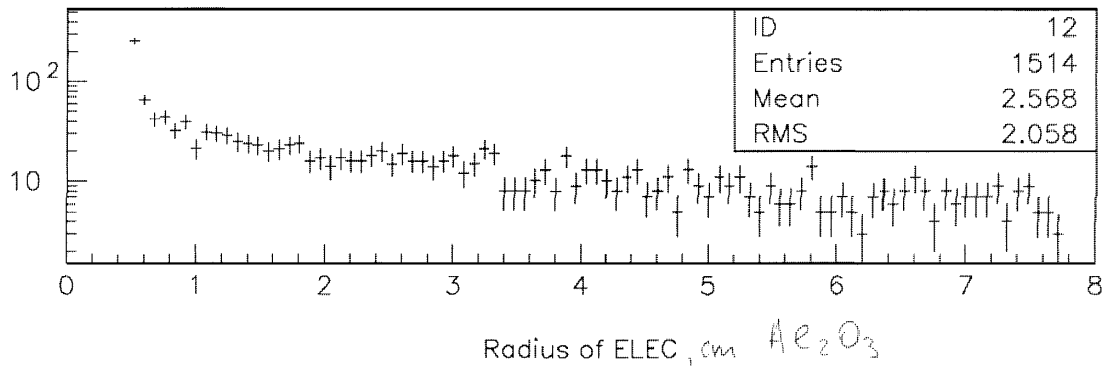

Fig. 5: Entries versus radius of the scintillator

Entries

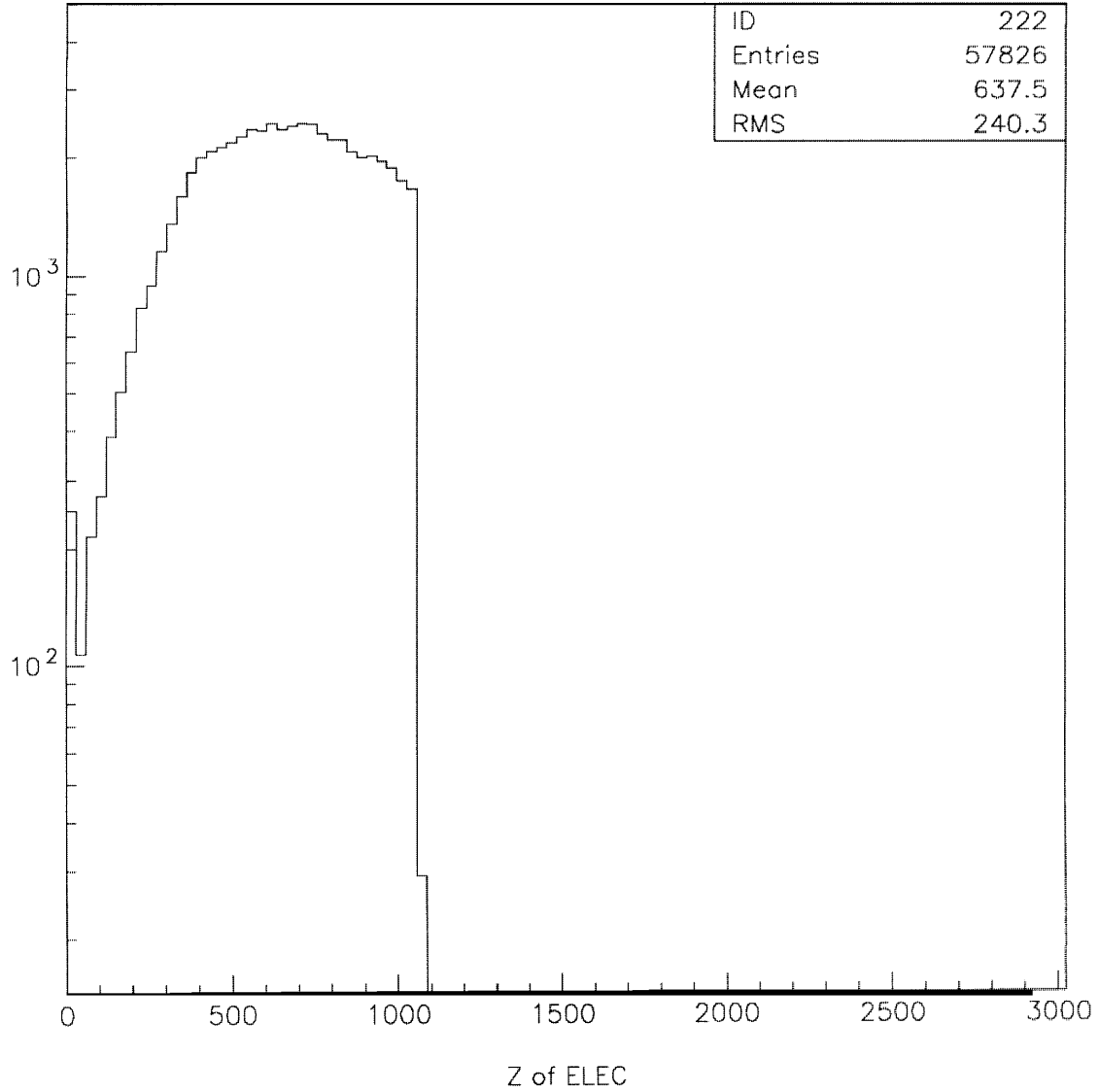

Fig. 6: Entries in the vacuum pipe versus distance z [cm]

B) Simulation results of the Bremsstrahlungs measurement

The geometry used in the GEANT program is shown in Fig. 7. The distance of the shower counter is about 15.60 m to the last wire scanner. The other three pairs of scanners were located every 4.8 m each. Behind the vacuum window the photons are tracked the last 5 m in air. The vacuum window was simulated as a 3-cm thick block of Aluminum. The table 3 shows the results for all scanner locations. The energy deposition E_{dep} in the detector (assumed: a 1.5 cm³ BGO block) and the number of Bremsstrahlungs photons $N_{\gamma, \text{det}}$ reaching the detector and the end of the beam pipe $N_{\gamma, \text{end}}$ were calculated. The number of primary electrons that hit the center of the wire was always assumed to be 10^6 , the wire material was ceramic.

Distance [m]	$E_{\text{dep}} [\text{MeV}] / 10^6 e^-$	$N_{\gamma, \text{det}} / 10^6 e^-$	$N_{\gamma, \text{end}} / 10^6 e^-$
15.60	202	11	25
20.40	172	4	15
25.20	112	3	11
30.00	0	0	7

Table 3

The signal at the shower counter at different positions of the wire (σ =beam width) for a bunch with 10^9 electrons is shown in table 4 (at 15.60 m).

Position of the wire	Electrons hitting the wire	$E_{\text{dep}} [\text{MeV}/\text{bunch}]$	$N_{\gamma, \text{det}}/\text{bunch}$
center	$2.75 \cdot 10^8$	$5.55 \cdot 10^4$	3025
1σ	$1.69 \cdot 10^8$	$2.9 \cdot 10^4$	676
2σ	$0.375 \cdot 10^8$	$0.42 \cdot 10^4$	113
3σ	$0.031 \cdot 10^8$	0	0

Table 4

The energy deposition is sufficient for a measurement, but the simulated number of photons reaching the detector is on the edge of the statistic relevance, specially at beam currents lower than designed. Therefore a big uncertainty has to be taken into account. The comparison between $N_{\gamma, \text{det}}$ and $N_{\gamma, \text{end}}$ shows that the 3 cm vacuum window is not responsible for the low number of Bremsstrahlungs photons. The opening angle of the radiation is much bigger than the solid angle covered by the detector (and the window). At low beam currents, this type of measurement may not give very precise results.

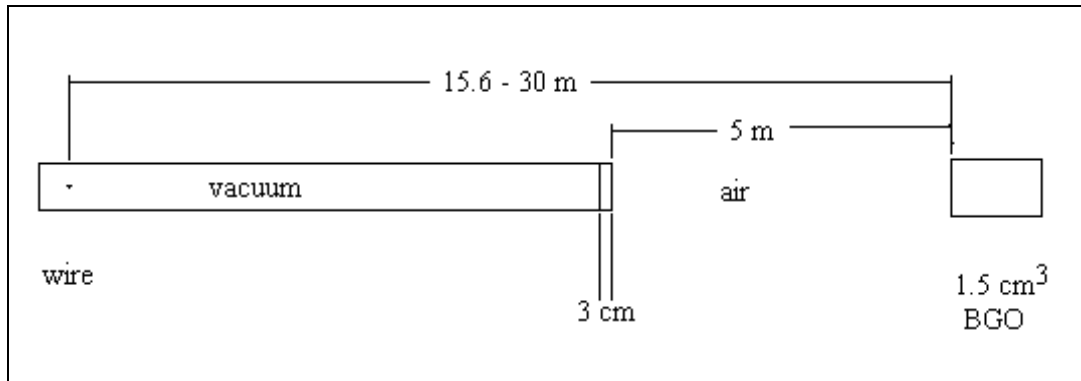

Fig. 7: Geometry for the Bremsstrahlung-simulation

B.1 Analytical results and comparison with Monte Carlo

To check results of simulation we perform an analytical estimations of the total number of photons $N_{\gamma, \text{tot}}$ and numbers of photons reaching end of the beam pipe $N_{\gamma, \text{end}}$. The energy of beam electrons is high enough to use simple total screening formulae from [Ref. 6] for the energy spectrum of Bremsstrahlung photons.

$$\frac{dN_g}{dn} = \frac{x}{X_0} \cdot \left(\frac{4}{3} - \frac{4}{3} \cdot n + n^2 \right)$$

where x is the target thickness, X_0 is radiation length of ceramic, i. e. for ceramic $X_0 = 7.02 \text{ cm}$, $v = \varepsilon/E_0$, ε and E_0 are the energies of the photon and the primary electron, respectively. Integration of the above

expression from the cut-off energy used in Monte Carlo simulation, $\varepsilon = 10$ keV, leads to $N_\gamma = 1.234 \cdot 10^{-3}$ photons/(incident electron). This result agrees within 10% with the Monte Carlo calculation (see Tab. 5).

The angular distribution of the Bremsstrahlung photons can be calculated by a rather simple and precise parameterization that is proposed in GEANT. The analytically calculated numbers of photon reaching the end of the beam pipe (using the approximations explained above) agree with simulated ones within the statistical errors (see Tab. 5).

Distance [cm]	$N_{\gamma, \text{tot}}$		$N_{\gamma, \text{end}}$	
	Monte Carlo	Analytical	Monte Carlo	Analytical
3000	1260	1234	7	5.4
2520	1341	1234	11	8.1
2040	1331	1234	15	13.5
1560	1361	1234	25	27
1560*	1249	1234	22.3	27

Table 5: Simulated and calculated number of Bremsstrahlung photons for a ceramic wire. All numbers based on 10^6 primary electrons except * which corresponds to 10^7 primary e^- .

B.2 Background due to residual gas

Since the number of Bremsstrahlung-photons is low, the background due to Bremsstrahlung from the residual gas may become important. A rough estimation is given by:

The number of Bremsstrahlung-photons N is proportional to $N \sim x/X_0$ with x = target length and X_0 = radiation length. For the ceramic wire, it is $x = d_1 = d \cdot \pi/4 = 5.5 \mu\text{m}$ and $X_0 = 7.0$ cm.

For the background, we assume a sensitive length of about $x = 30 \text{ m} = 30 \cdot 10^2$ cm, which is the part of the accelerator with a beam energy above 200 MeV. The mean pressure P in this area is assumed to be about 10^{-8} mbar and the main contribution of the residual gas is N_2 . Therefore the radiation length at 10^{-8} mbar (10^{-11} bar) is:

$$X_0 = L_{\text{rad}} / (\rho \cdot P) = 37.99 [\text{g}/\text{cm}^2] / (1.25 [\text{g}/1000 \text{ cm}^3] \cdot 10^{-11}) = 3.0 \cdot 10^{15} \text{ cm.}$$

Therefore the rate from the wire is a factor of

$$\frac{x / X_0 |_{\text{wire}}}{x / X_0 |_{\text{gas}}} = \frac{5.5 \cdot 10^{-4} / 7.0}{30 \cdot 10^2 / 3 \cdot 10^{15}} = \frac{7.85 \cdot 10^{-5}}{1 \cdot 10^{-12}} = 7.85 \cdot 10^7$$

higher than from the background which is a good signal to noise ratio.

C Secondary emission Signal

The secondary emission of electrons from the wire is proportional to the number of beam particles hitting the wire, creates a current in the conducting wire material. This secondary emission measurement mode is useful mainly at very low energy proton/ion accelerators, where the scattered particles are stopped in the beam pipe wall (Ref. 4). In this case a scintillator located outside of the vacuum pipe will not give sufficient signal. The typical secondary emissions coefficients are around 3-7 % for Carbon (Ref. 5; let us assume 3%). The following table shows the signal at different wire locations with respect to the beam center:

Position of the wire	Electrons hitting the wire(TTF FEL)	Secondary electrons [e-/bunch]
center	$2.75 \cdot 10^8$	$5.55 \cdot 10^6$
1σ	$1.69 \cdot 10^8$	$3.38 \cdot 10^6$
2σ	$0.375 \cdot 10^8$	$0.75 \cdot 10^6$
3σ	$0.031 \cdot 10^8$	$0.06 \cdot 10^6$

Table 5

At high currents this type of measurement will be distorted by thermal emission of electrons so that it can only be used at very low currents.

Temperature of the wire due to heat load of the electron beam

Due to the fact, that the beam size for the 1 nC beam (TTF FEL) is a factor 3 smaller than for the 8 nC beam (TTF) with the same number of electrons/macro pulse, we discuss in the following the more critical case of the 1 nC beam.

We distinguish between three scanning modes:

1. Fast scan:

During a scan, a part of the wire will be heated by the energy loss dE/dx of the electrons. The energy loss/electron dE/dx is 4.03 MeV/cm/electron for carbon. The resulting maximum wire temperature T_{\max} depends on the LINAC parameters and on the scanning speed v . It can be estimated by (Ref. 5):

$$T_{\max} = 3.8 \cdot 10^{-14} \cdot dE/dx \cdot d \cdot \pi/4 \cdot N / (c_p \cdot G) \cdot (d \cdot F / v) \cdot a_{\text{sec}}$$

With:

$$1 \text{ MeV} = 3.8 \cdot 10^{-14} \text{ cal}$$

Specific heat capacity: $c_p = 0.283 \text{ cal}/(^{\circ}\text{C g})$ (carbon wire)

Weight of the heated portion of the wire: $G = 2 \sigma d^2/4 \pi \rho$

Density of the wire: $\rho = 2.265 \text{ g/cm}^3$ (carbon wire) and $d \cdot \pi/4 =$ mean diameter of the wire.

N and F depend on the 'mode' of the scan, which depends on the required speed of the wire.

Note that the maximum temperature does not depend on the wire diameter d . The emission of secondary particles will reduce T_{\max} by up to about 70% ($a_{\text{sec}} = 0.3$). Radiation cooling and heat transport are not taken into account because the heat dissipates slowly from the wire, compared with the macro pulse length, due to the small surface area and diameter of the wire.

The fastest speed of the wire is

$$v_{\text{fast}} = 1 \text{ m/s and } N = N_b ; F = F_b.$$

With this high speed, there must be a precise synchronization between the position of the wire and the beam timing to get the beam hitting the wire. The resulting maximum theoretical temperature T_{\max} is $4.0 \cdot 10^3 \text{ }^{\circ}\text{C}$, which is about 10% above the melting point of carbon ($3700 \text{ }^{\circ}\text{C}$). In this mode the total current has to be 10% lower than the design current to keep the wire.

2. No scanning; the wire will be moved in steps to different positions in the transverse beam profile.

The maximum heat load will be on the wire if it is in the beam center. Therefore we estimate the heat load at the beam center (for one macro pulse):

The temperature increase for each single bunch passage is:

$$\Delta T/\text{bunch} = 3.8 \cdot 10^{-14} \cdot dE/dx \cdot d \cdot \pi/4 \cdot N_b / (c_p \cdot G) \cdot a_{\text{sec}}$$

With $N = 2.75 \cdot 10^8$ (beam center, see table 2) the increase for one bunch is $\Delta T_{\text{bunch}} = 2.2 \text{ }^{\circ}\text{C}$. Therefore the wire will survive about 1600 bunches within one macro-pulses before melting. The equilibrium temperature for this situation at a repetition frequency of 10 Hz is about $1650 \text{ }^{\circ}\text{C}$ while it is at 1 Hz about $930 \text{ }^{\circ}\text{C}$. The maximum temperature can be estimated by adding the instantaneous temperature increase to the average temperature. Therefore one would get with $F_p = 1 \text{ Hz}$ about $1000 \text{ }^{\circ}\text{C}$ for 1000 bunches/macro pulse while with $F_p = 10 \text{ Hz}$ and 500 bunches/macro pulse one would expect about $2700 \text{ }^{\circ}\text{C}$. In both cases the temperature keeps below the melting point of carbon. We can conclude, that with a pulse length of $30 \text{ } \mu\text{s}$ at 9 MHz (270 bunches) and a charge of 1 nC/bunch and a repetition rate of 1 Hz and 10 Hz, a save operation is possible within a safety margin of factor 2.

3. A third possibility is to scan the LINAC beam in small steps of about 1 mm/macro pulse:

$$v_{\text{slow}} = 1 \text{ } \mu\text{m} \cdot F_p = 10 \text{ } \mu\text{m/s and } N = N_p ; F = F_p.$$

The maximum temperature of the wire will be $T_{\max} = 3.2 \cdot 10^6 \text{ }^{\circ}\text{C}$ (assuming no cooling). In this case the radiation cooling (Stephan Boltzmann law, $T_{\text{eq}} = ? E/sa$; $E = dE/dx \cdot d \cdot 4/\pi \cdot N_b \cdot F_p$; $sa = 35.4 \cdot 2\sigma \cdot \pi \cdot d/2$) gives a significant reduction of the mean temperature. The equilibrium temperature is about $2700 \text{ }^{\circ}\text{C}$. But the instantaneously temperature will be much bigger. Without taking into account any cooling mechanism, the maximum number of electrons the wire can survive is then about $5 \cdot 10^{10}$ electrons/macro pulse or 10 bunches/macro pulse with design current only with $F_p = 10 \text{ Hz}$ during the scanning time.

Conclusions

The most useful readout scheme of the wire scanners at the TTF-FEL can be performed with the scintillator paddles behind each scanner location. The signal is big enough to give useful information down to $\pm 3\sigma$ at a bunch current of about 10^8 e⁻/bunch. One might gain an additional factor 10 by reading out the scintillator of the following scanners because of the increasing number of electrons hitting the vacuum pipe at larger distances. Therefore, for the last scanner, it can be useful to install a fifth scintillator about 5-10 m downstream. This will be tested after the installation of the undulator.

The signal obtained from the detection of the Bremsstrahlungs-photons will give useful results at higher beam currents only ($>10^9$ e⁻/bunch). The efficiency of detecting Bremsstrahlungs photons far downstream is low.

The secondary emission mode is restricted to conducting materials as well as to low currents. At high currents, thermal electrons distort the signal. A very sensitive amplifier will be needed to observe the signal. However, tests are foreseen.

It will be not allowed to make wire scans at design currents and with the FEL running. The electron beam and the photon beam melt the wire under these conditions. The FEL process can be reduced by separating the photon beam from the electron beam so that the SASE process does not start or by reducing the charge to 1/10 of the design current, so that the wire will survive scans with a speed of 1 m/s. Very low speed scans should be done with up to 300 bunches / macro-pulse only (safety margin of 2) or with a small macro-pulses - repetition rate of less or equal to 1Hz at up to 100% of the design beam charge.

References

- 1) K. Wittenburg, H. Schultz;
Deutsches Elektronen Synchrotron, DESY; **A Proposal for using Wire-Scanners at the LINAC Test Facilities**; DESY-TESLA 94-15 (1994)
- 2) G. Schmidt, U.Hahn, J. Plüger;
Concept of electron beam diagnostic for VUV SASE FEL at TESLA test facility (TTF FEL) at DESY. to be published in Nucl. Instr. & Meth. A. DESY-TESLA-FEL-98-06L, Sep 1998
- 3) Application Software Group. CERN - CN Division, **GEANT - Detector Description and Simulation Tool 13**
- 4) Elmfors, P; Fassò, A ; Huhtinen, M ; Lindroos, M ; Olsfors, J ; Raich, U
Wire scanners in low energy accelerators. Publ.: Nucl. Instrum. Methods, Phys. Res., A: 396 (1-2) (1997) 13-22. (20 p). 1997 and CERN-PS-97-004-OP; CERN-TH-96-272.
- 5) K. Wittenburg
Deutsches Elektronen Synchrotron, DESY
Strahlprofilmonitore für den HERA – Protonenring; DESY HERA 1986 - 06 (May 1986), 55 p.
- 6) Tsai Y.-S.
Pair Production and Bremsstrahlung of charged leptons. Review of Modern Physics, 1974, v.46, p.815 -- 851.